

Force detecting gripper and flexible micro manipulator for neurosurgery.

メタデータ	言語: English 出版者: 公開日: 2017-10-03 キーワード (Ja): キーワード (En): 作成者: Yoneyama, Takeshi, Watanabe, Tetsuyou, Kagawa, Hiroyuki, Hamada, Jun-ichiro, Hayashi, Yutaka, Nakada, Mitsutoshi, 米山, 猛, 渡辺, 哲陽, 香川, 博之, 濱田, 潤一郎, 林, 裕, 中田, 光俊 メールアドレス: 所属:
URL	https://doi.org/10.24517/00008705

This work is licensed under a Creative Commons Attribution-NonCommercial-ShareAlike 3.0 International License.



Force Detecting Gripper and Flexible Micro Manipulator for Neurosurgery

T.Yoneyama, T.Watanabe, H.Kagawa, J.Hamada, Y.Hayashi and M.Nakada

Abstract—In order to realize a less invasive robotic neurosurgery for the deeply seated tumor, a force detecting gripper with a flexible micro manipulator has been developed. Gripping force applied on the gripper is detected by strain gages fit on the gripper clip. Signal is conducted to the amplifier by the cables through the inner pipe of the manipulator. In order to approach to the deeply seated tumor through a narrow hole, a micro manipulator which can flex at the end part to face the gripper for the target and can rotate the closing direction of the gripper at the end of the manipulator has been developed. Some operation test showed that the developed manipulator can approach flexibly to the target, and the taking out force of a target on the soft material was detected clearly.

I. INTRODUCTION

FOR the less invasive surgery, operation using manipulator with endoscope became popular and surgical robotics has been also widely used in the field of abdominal and urological surgeries[1]- [3]. But more high performance is necessary in the robotic operation system for the neurosurgery [4]. Concerning the robot surgery for the resection of the deep seated tumor, Hongo et al. [5] [6], Kan et al. [7], Morita et al.[8] and Arata et al. [9] have been developing robotic neurosurgery system, but there is still not a force detecting gripper and enough flexibility in the micro manipulator.

For the purpose of taking out the brain tumor in the deep narrow space, flexible micro manipulator should be useful. The micro manipulator will be operated by master-slave control system. In this system, one of the important functions is the transfer of the gripping and operating force from the manipulator to the operating doctor. It is quite different from the directly operated forceps that the gripping force and picking out force cannot be conducted directly to the operating doctor by the micro manipulator. Force detection at the gripper is quite necessary in the micromanipulator in order to transfer the feeling of the operating force to the doctor. Therefore force detecting gripper for the micro manipulator is designed and fabricated in this study.

Another important function of the micromanipulator is the flexibility in the direction and motion at the end of the manipulator. In order to grip or excavate the tumor from the

appropriate direction, the gripper should be approached to the tumor from various directions. For this purpose, the end part of the manipulator should be flexed and the gripper should be rotated in the flexed axis at the end of the manipulator tube. Such flexible mechanism has been designed and fabricated.

II. DESIGN TARGET ON THE GRIPPER AND MANIPULATOR

A. Situation about the taking out of tumor

In order to take out the deeply seated lesion in the brain under the less invasive surgery, it is desired that micromanipulators, endoscope and vacuum pipe are inserted through the integrated surgery pipe and conducted to the operating field as shown in Fig.1.

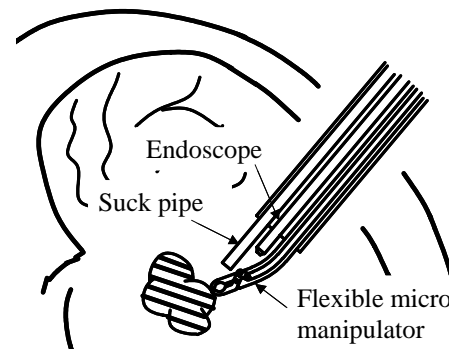

Fig.1. Desired manipulator system to take out the deeply seated tumor in the neurosurgery

The main operations to take out the brain tumor will be as follows.

- (1) Approach the gripper to the tumor surface
- (2) Insertion of the gripper to the tumor region
- (3) Grip the part of the tumor
- (4) Pull out the tumor piece
- (5) Take the tumor to the vacuum pipe entrance
- (6) Open the gripper to suck the tumor chip through the vacuum pipe

B. Design target on the gripper and manipulator

Toward the force detecting gripper with flexible micro manipulator, following functions are set as targets in this study.

- (1) Diameter of the flexible tube and that of the closed gripper are about 3mm
- (2) The manipulator can bend its end part to apply the gripper toward the tumor target

This study was supported by the Grants-in-Aid for Scientific Research from Japan Society for the Promotion of Science.

T.Yoneyama, T.Watanabe and H.Kagawa are with the College of Science and Engineering, Kanazawa University, Kakuma-machi, Kanazawa, 920-1192 Japan (e-mail: yoneyama@t.kanazawa-u.ac.jp).

J.Hamada, Y.Hayashi and M.Nakada are with the Department of Neurosurgery Graduate School of Medical Science, Kanazawa University, Takara-machi, Kanazawa, 920-8641, Japan

- (3) The gripper can rotate at the end of the manipulator around the bent axis in order to change the gripping direction.
- (4) The gripper detects the grasping force and pulling force.

II. DESIGN AND FABRICATION OF GRIPPER

A. Grip force detection structure

Mechanism and structure of the force detecting gripper is shown in Fig.2. As the main forceps for neurosurgery, a cup type forceps are chosen. This forceps consist of a pair of fixed clip and movable clip. Movable clip is operated by the link connected with the inner pipe. The gripper closes when the central pipe is pulled. Force detecting structure is installed in the fixed clip. The detail figure of the fixed clip with strain gages is shown in Fig.3. From the primary test on the gripping of soft material, maximum force is expected about 1N for both gripping and pulling. An example of the FEM analysis on the grip force detection is shown in Fig.4. Parallel plates in the fixed clip deforms elastically by the gripping force. Strain gages fit on the plate surface detect the surface strain on the plate in the clip as the change of electric resistance. On the other hand, to detect the pulling force by

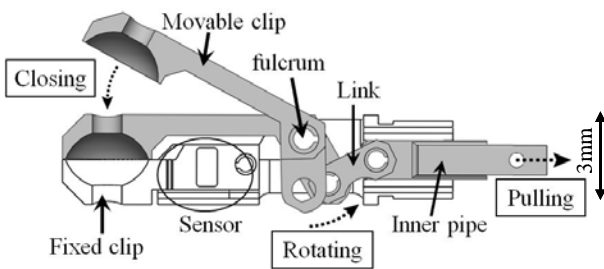

Fig.2. Setup of the gripper

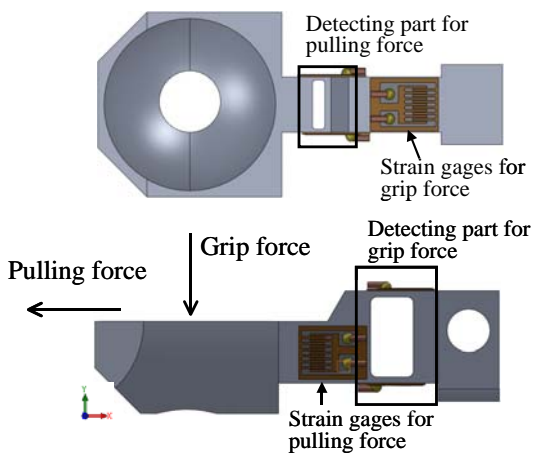

Fig.3. Detail structure of the force detecting clip

the gripper, another thin plates structure is made in other direction on the different position in the fixed clip. By the pulling or pushing force, tensile or compressive stress occurs on this surface. Strain gages are also fit on this surface. All the parts were made of stainless steel.

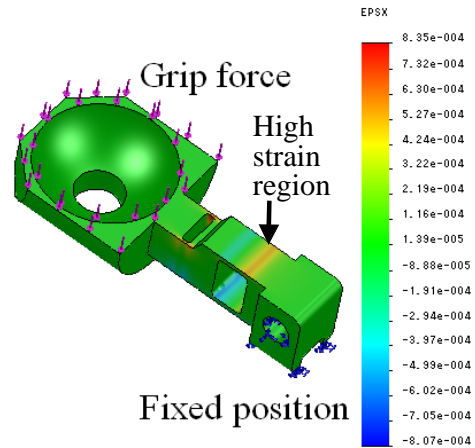

Fig.4. Strain analysis on the detection clip

B. Strain gage fitting and wiring

Commercial strain gages are adopted to the detecting part. Used strain gage is KFR-02N-120-C1-16 of Kyowa Strain Gages which base size is 1.6mm×1.2mm. Because the size of the detection block is small, base film of the strain gage are cut around periphery and fit on the detecting position. The machined detection block with fit strain gages is shown in Fig.5. The lead wires from the strain gage were took around the link and conducted to the central hole in the inner pipe.

Constructed gripper is shown in Fig.6. Movable clip and other links were connected by spring pins. Sensor part in the fixed clip is covered with the holder that is connected with outer pipe with rotation free.



Fig.5. Manufactured clip and fit strain gages



Fig.6. Constructed gripper

C. Force calibration

Output performance of the force detecting clip has been examined. Detected strain for the 1N gripping force was 500×10^{-6} and interference from the pulling force is negligible. Output strain for the 1N pulling force is about 50×10^{-6} and interference from the gripping force was little bit large. To obtain the real gripping force and pulling force in the situation of combined force, calibration matrix is applied on the detected outputs. Force resolution may be 0.01N for the gripping force and 0.1N for the pulling force.

III. FLEXIBLE MICRO MANIPULATOR

A. Total structure

Flexible micro manipulator consists of outer flexible tube with wires and inner flexible pipe as shown in Fig.7. The flexible part in the outer tube is made of thin plates connected with rings. Using electro discharge machining, this structure was made from a single tube. Tube material is super elastic metal named as “Gum Metal” [10] which is beta-type titanium alloy developed by Toyota Central R & D laboratory. The elastic strain limit is 2.5% and Young’s Modulus is 45GPa. Two stainless wires were inserted into the small tubes which were fixed in the grooves cut on the side surface of the rings and the terminals of the wires were fixed at the end of the flexible tube as shown in Fig.8. If the one side wire is pulled, the flexible tube bends to the pulled wire direction. Simulated deformation of the flexible tube and actual flexion test example are shown in Fig.9. Simulated bending range was 44 degrees. On the other hand, actual angle was 22

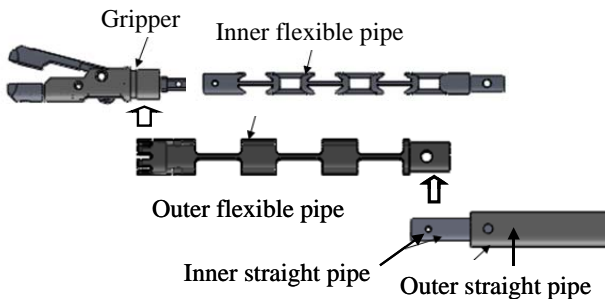

Fig.7. Structure of the flexible part in the manipulator

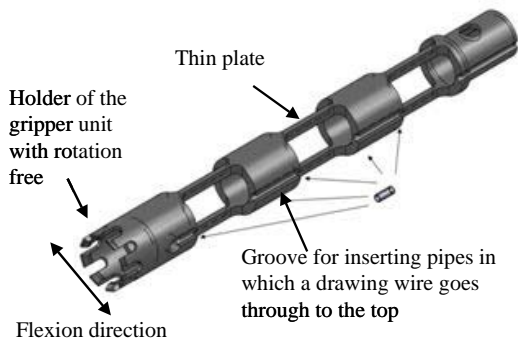

Fig.8. Structure of the flexible outer pipe

degrees by the same force of the drawing wire. Bending flexibility will be improved by the wire holding structure.

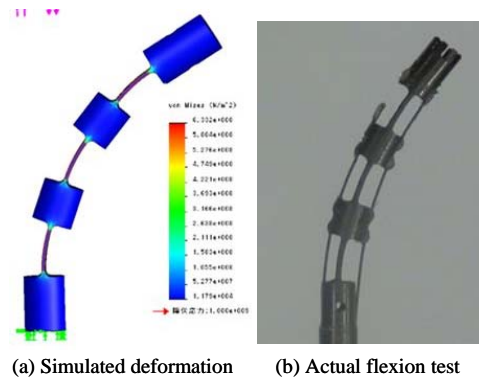

Fig.9. Deformation analysis and actual deformation of the outer pipe

The structure of the inner flexible pipe is shown in Fig.10. Because the inner pipe is rotated in the flexed outer tube, it must be flexible in two directions. Therefore thin plate parts for one direction and others for the perpendicular direction are arranged one after the other. The flexible part of the inner pipe is also made of “Gum metal” Actual flexion example is shown in Fig.11.

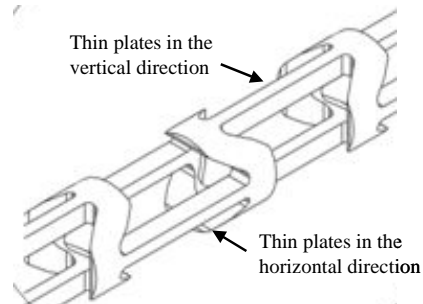

Fig.10. Flexion structure of the inner pipe



Fig.11. Flexion test of the inner pipe

B. Flexion performance

As the flexion mechanism is elastic deformation of thin plates, there is a limit of flexion angle owing to the elastic criteria of the material. Assembled gripper and tubes are shown in Fig. 12. Actual flexed example of the combined inner pipe and outer pipe by the pulling wire is shown in Fig.13. The rotation of the gripper at the end of flexed manipulator is shown in Fig.14. The limit of the flexion angle is 22 degrees by the 8N force by the pulling wire.



Fig.12 Assembled gripper and micro manipulator

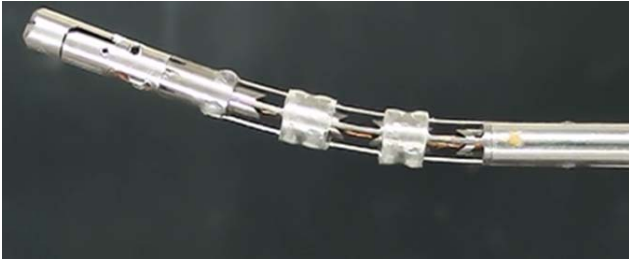

Fig.13. Flexion of the assembled micro manipulator by pulling the wire through the outer pipe

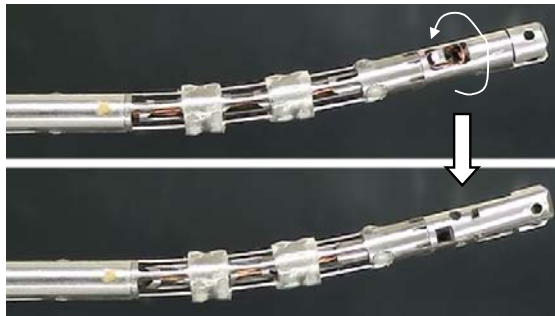

Fig.14. Rotation of the gripper at the end of flexed manipulator

IV. EXPERIMENT AND RESULTS

A. Operating system

As a first step experiment, operation of the grasping a target on the soft material using the master-slave operating system has been carried out. Slave driving unit is shown in Fig.15. All the micro manipulator motions are driven by stepping motors. There are motors for closing the gripper, rotation of the gripper at the flexed manipulator end, flexion of the end part of the manipulator, rotation of the manipulator at the backside and forward-backward motion.

Operating devise is shown in Fig.16. All the operating motions are assisted by stepping motors. Grasping force, rotation torque of the joystick and feed force are detected to feedback the forces to the surgeons.

There are two control modes for the proposed system; one is unilateral mode where the motion of the master manipulator is transmitted to the slave manipulator but the force exerted on the slave manipulator are not fed back to the operator, the other is bilateral mode where the master motion is transmitted to the slave manipulator while the force exerted on the slave manipulator is fed back and the operator can feel the forces such as gripping force and contact force. In the following experiment, unilateral mode is used only to know

the motion performance and force detecting performance of the micromanipulator.

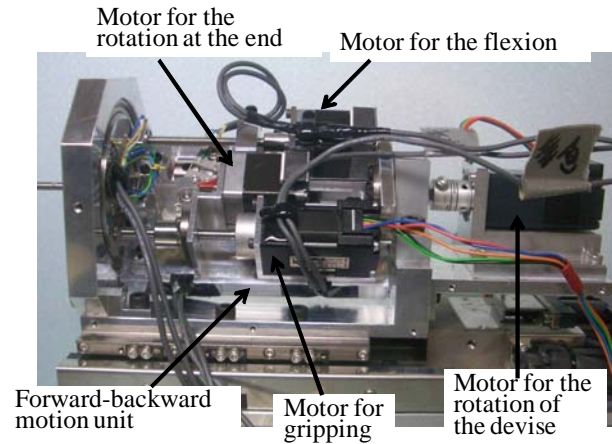

Fig.15 Slave manipulator driving devise

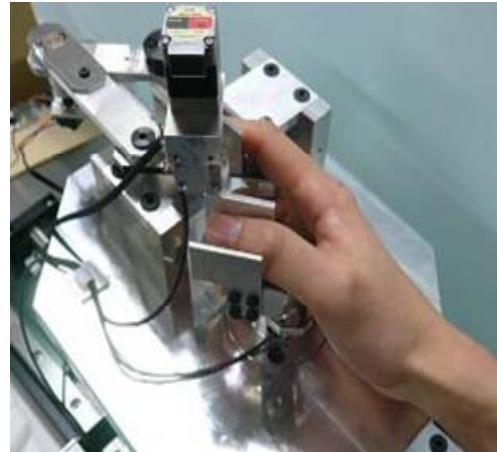

Fig.16 Operating devise

B. Motion of the manipulator

Operation test to take out some target on the soft material "tofu" has been carried out. As the target was set in the different position from the axis of straight manipulator, the operator bend outer tube and rotate the tube with forward motion. Thus the gripper is approached to the target. After the inner pipe is rotated to change the gripper closing direction, the manipulator is inserted to the soft material and then the gripper is closed by pulling the inner pipe. The hard target on the soft material is grasped by the gripper and took out from the surface.

All these motions are operated by driving motors at the end of micro manipulator and the motions are controlled by the master manipulator system operated by a doctor. The doctor operated the master manipulator looking at monitor screen. The picture on the monitor is shown in Fig.17.

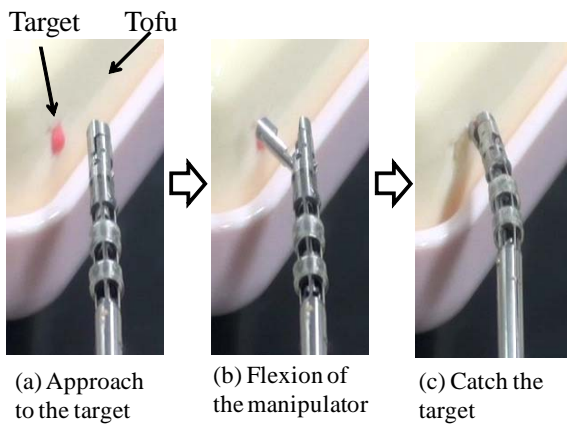

Fig.17. Operation test to catch a target on the soft material surface

C. Force detection during drawing the target

An example of the gripping force and pulling force detected during the grasping and pulling soft material is shown in Fig. 18. At first, the gripper is pushed on the material and the pulling force is detected negative. Then the gripper grasped the material and pulled. Gripping force increased and then gradually decreased as the pulling distance. Pulling force also increases and then gradually decreased may be due to the slip between the gripper and the material. Accuracy of the pulling force and various cases of the pulling force should be investigated more from now.

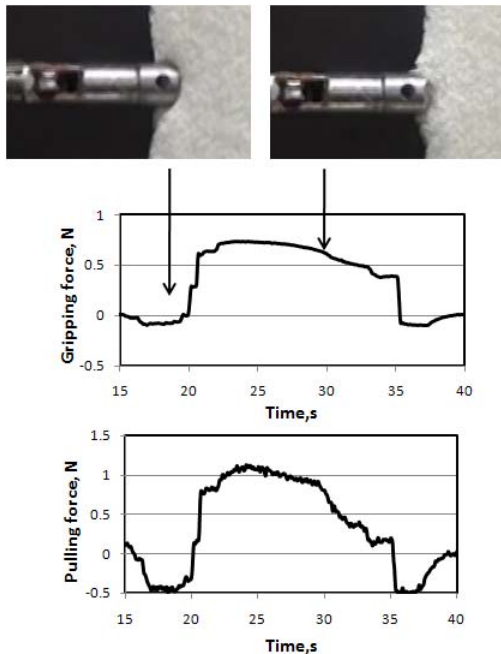

Fig.18. Gripping force and pulling force during the grasping and pulling soft material

V. FUTURE WORK

In this study, force detecting gripper which can detect gripping force and pulling force has been developed and some primary test results are shown. Accuracy of these force detections must be further examined. Flexible micro manipulator which can be flexed and rotated at the end of the manipulator has been also developed and the grasping the target by the flexible motion has been succeeded.

The operating system using the force detecting gripper is now in the progress. The operator will be able to feel the gripping force resistance on the master handle corresponding to the gripping force at the gripper. It will assist the operator's feeling and judgment during the picking out the tumor.

The increase in the elastic limit performance of the metal material and improvement of the dimensions of the thin plates structure with drawing wire selection will increase the flexion performance of the manipulator. Stiffness of the flexion part will be also improved by the investigation on the design of the flexion structure.

ACKNOWLEDGMENT

The authors would like to thank K.Azuma, Y.Yamashita, Y.Tanaka, Y.Fujihira, T.Osawa, K.Tanaka, W.Ueno, T.Fujii, N.Sugiyama for their effort to develop the manipulator system.

REFERENCES

- [1] CN.Gutt, T.Onui, A.Mehrabi,A.Kashfi, P.Schemmer and MW. Schemmer, "Robot-assisted abdominal surgery," *Br. J. Surgery*, 91, 2004, pp.1390-1397.
- [2] S. Jacobs, V.Falk, "Pearls and pitfalls:Lesions learned in endoscopic robotic surgery-the da Vinci experience," *Heart Surgery Forum* 4,2001, pp. 307-310.
- [3] DD.Thiel, HN.Winfield, "Robotics in urology:Past, present, and future." *J. Endourol*, 22, 2008, pp.825-830.
- [4] T.Haidegger, L.Kovacs, G.Fordos, Z.Bnyo and P.Kazanzides, "Future Trends in Robotic Neurosurgery." *14th Nordic-Baltic Conference on Biomedical Engineering and Medical Physics* 2008, pp.229-233.
- [5] K.Hongo, Y.Kakizawa, J.Koyama, K.Nishizawa, F.Tajima, MG.Fujie and S.Kobayashi, "Microscopic-manipulator system for minimally invasive neurosurgery." *Computer Assisted Radiology and Surgery*, Amsterdam, Excerpta Medica, 2001, pp.265-269.
- [6] K.Hongo, S.Kobayashi, Y.Kakizawa, J.Koyama, T.Goto, H.Okudera, K.Kan, MG.Fujie, H.Iseki and K.Takakura, "Neurobot:Telecontrolled micromanipulator system for minimally invasive microneurosurgery." *Neurosurgery* 51, 2002, pp.985-988.
- [7] K.Kan, MG. Fujie, F.Tajima, K.Nishizawa, T.Kawai, A.Shose, K.Takakura, S.Kobayashi and T.Dohi, "Development of minimally invasive neurosurgery." *Computer Assisted Radiology and Surgery*, Amsterdam, Excerpta Medica, 2001, pp.144-149.
- [8] A.Morita, S.Sora, M.Mitsuishi, S.Warisawa, K.Suruman, D.Asai, J.Arata, S.Baba, H.Takahashi, R.Mochizuki and T. Kirino, "Microsurgical robotic system for the deep surgical field:Development of a prototype and feasibility studies in animal and cadaveric models." *J. Neurosurgery* 103, 2005, pp.320-327.
- [9] J.Arata, Y.Tada, H.Kozuka, T.Wada, Y.Saito, N.Ikedo,Y.Hayashi, M. Fujii, Y.Kajita, M.Mizuno, T.Wakabayashi and H.Fujimoto, "Neurosurgical robotic system for brain tumor removal." *Int. J. Computer Assisted Radiology and Surgery* 6, 2011, pp.375-385.
- [10] http://www.toyotsumaterial.co.jp/en/jigyo/jigyo_05.html