

## Implementing Ohmmeter/Temperature Sensor

Author: Doug Cox  
Microchip Technology, Inc.

### INTRODUCTION

This application note describes a method for implementing an ohmmeter or resistance type temperature sensor using the PIC16C5X series of microcontrollers. The ohmmeter requires only two external components and is software and hardware configurable for resistance measurement with resolutions from 6-bits to 10-bits with measurement times of 250  $\mu$ s (6-bits at 8 MHz) or longer. This method uses a software calibration technique that compensates for voltage, time, and temperature drift as well as component errors. PIC16C5X microcontrollers are ideal for simple analog applications because:

- Very low cost
- Few external components required
- Fully programmable. PIC16C5X Microcontrollers are offered as One Time Programmable (OTP) EPROM devices.
- Available off the shelf from distributors
- Calibration in software for improved measurement accuracy
- Power savings using PIC16C5X's Sleep mode.
- PIC16C5X's output pins have large, current source/sink capability to drive LED's directly.

### THEORY OF OPERATION

This application uses a capacitive charging circuit (Figure 1) to convert resistance to time, which can be easily measured using a microcontroller. First, a reference voltage (usually VDD) is applied to a calibration resistor, R<sub>c</sub>. The capacitor C is charged up until the threshold on the chip input trips. This generates a software calibration value that is used to calibrate out most circuit errors, including inaccuracies in the capacitor, changes in the input threshold voltage and temperature variations. After C is discharged, the reference voltage is applied to the resistance to be measured (or thermistor). The time to trip the threshold is then measured and compared to the calibration value to determine the actual resistance (Figure 2). In the temperature sensing mode, the temperature is calculated using a lookup table.

**FIGURE 1: OHMMETER/TEMPERATURE SENSOR**

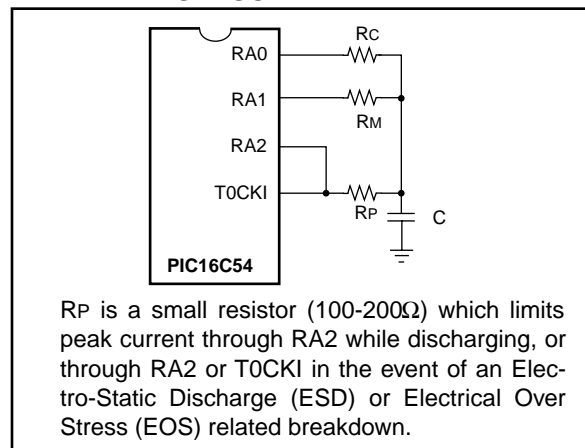

**FIGURE 2: OHMMETER/TEMPERATURE SENSOR**

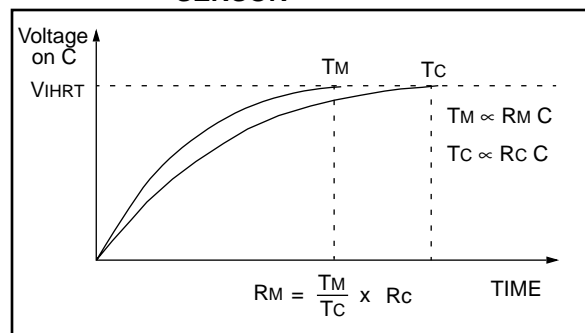

## CIRCUIT CONFIGURATION

The values of  $R_c$  and  $C$  are selected based upon the number of bits of resolution required.  $R_c$  should be approximately one half the largest value resistance to be measured and:

$$C = \frac{-T}{R_M \cdot \ln\left(1 - \frac{V_T}{V_R}\right)}$$

Where:

$V_R$  = Reference voltage

$T$  = Time to do the number of bits of resolution desired

$V_T$  = Threshold voltage of the PIC16C5X input being used

$R_M$  = Maximum resistance value to be measured

Actual value for  $C$  should be slightly smaller than calculated to ensure that the PIC16C5X does not overcount during the measurement.

For example use  $R_M = 200k$  for 8-bit resolution with an 8 MHz clock,  $V_R = 5V$ ,  $V_T = 3V$ ,  $R_c = 100k$  and 6 instruction cycles per count:

$$T = 256 \text{ counts} \cdot 1/8 \text{ MHz} \cdot 4 \text{ clocks/instruction} \cdot 6 \text{ instructions/count} = 768 \mu\text{s}$$

$$C = 4200 \text{ pF [Use 3900 pF]}$$

## CIRCUIT PERFORMANCE

The calibration cycle removes all first order errors (offset, gain,  $C$  inaccuracy, power supply voltage and temperature) except  $R$  absolute accuracy. A low drift resistor should be selected for  $R$  and its value stored in software to reduce measurement errors. Other error sources are I/O pin leakage, resistor and capacitor non-linearities, input threshold uncertainty, and time measurement uncertainty ( $\pm$  one instruction cycle time). Measured performance shows the ohmmeter to be accurate within  $\pm 1\%$  over one decade.

### Example

The assembly code implementing the circuit of Figure 1 is listed in Appendix A. This code measures time up to 16-bits (65535 measure cycles) and calculates the results using 16-bit multiply and divide subroutines. In actual applications, it is more efficient to use 8-bit measurements if application accuracies permit. The math code will be substantially reduced and measurement time is reduced by the simpler code and shorter count.

FIGURE 3: TRANSMISSION FLOWCHART

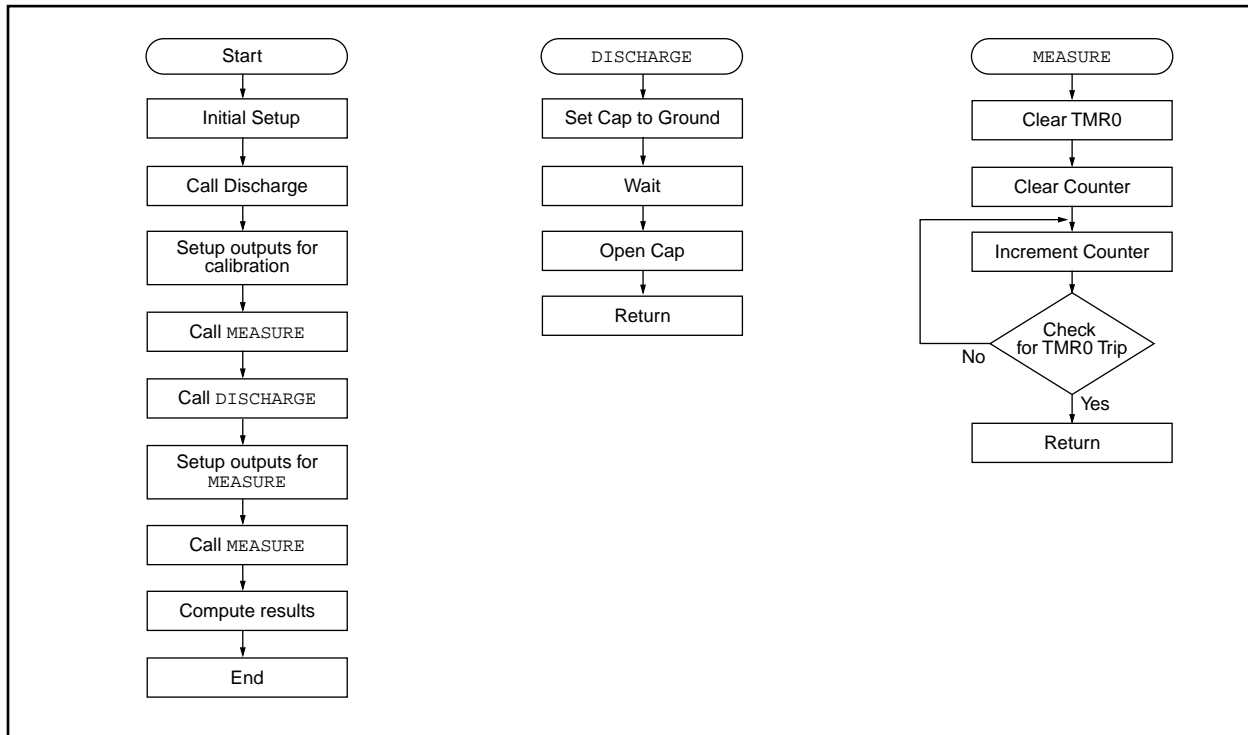

Please check the Microchip BBS for the latest version of the source code. Microchip's Worldwide Web Address: [www.microchip.com](http://www.microchip.com); Bulletin Board Support: MCHIPBBS using CompuServe® (CompuServe membership not required).

## APPENDIX A: OHMETER SOURCE CODE

MPASM 01.40 Released

OHMETER.ASM 1-16-1997 12:31:45

PAGE 1

```

LOC OBJECT CODE      LINE SOURCE TEXT
VALUE

00001          TITLE  'OHMETER/TEMPERATURE SENSING PROGRAM REV 3-29-90'
00002          LIST   P=16C54
00003          ;
00004          ;*****
00005          ;
00006          ;      Program:          OHMETER.ASM
00007          ;      Revision Date:
00008          ;                               1-13-97      Compatibility with MPASMWIN 1.40
00009          ;
00010          ;*****
00011          ;
00000008      00012 ACCA  EQU    8
0000000A      00013 ACCB  EQU    0A
0000000C      00014 ACCC  EQU    0C
0000000E      00015 ACCD  EQU    0E
00000010      00016 ACCE  EQU    10
00000012      00017 TCAL  EQU    12
00000014      00018 TEMP  EQU    14
00019          ;
00000001      00020 F      EQU    1
00021          ;
0000002F      00022 RCALMS EQU    2F          ;RCAL MSB VALUE IN HEX
0000003C      00023 RCALLS EQU    3C          ;RCAL LSB VALUE IN HEX
00024
01FF          00025      ORG    1FF
01FF 0A58     00026      GOTO  OHMS
0000          00027      ORG    0
00028
0000 0209     00029 MADD  MOVF   ACCA+1,W
0001 01EB     00030      ADDWF  ACCB+1, F      ;ADD LSB
0002 0603     00031      BTFSC  3,0          ;ADD IN CARRY
0003 02AA     00032      INCF   ACCB, F
0004 0208     00033      MOVF   ACCA,W
0005 01EA     00034      ADDWF  ACCB, F      ;ADD MSB
0006 0800     00035      RETLW  0
0007 0000     00036      NOP
00037
0008 0915     00038 MPY   CALL   SETUP          ;RESULTS IN B(16 MSB'S) AND C(16 LSB'S)
0009 032E     00039 MLOOP RRF   ACCD, F      ;ROTATE D RIGHT
000A 032F     00040      RRF   ACCD+1, F
000B 0603     00041      SKPNC          ;NEED TO ADD?
000C 0900     00042      CALL   MADD
000D 032A     00043      RRF   ACCB, F
000E 032B     00044      RRF   ACCB+1, F
000F 032C     00045      RRF   ACCC, F
0010 032D     00046      RRF   ACCC+1, F
0011 02F4     00047      DECFSZ TEMP, F      ;LOOP UNTIL ALL BITS CHECKED
0012 0A09     00048      GOTO  MLOOP
0013 0800     00049      RETLW  0
00050
0014 0000     00051      NOP
0015 0C10     00052 SETUP  MOVLW  10
0016 0034     00053      MOVWF  TEMP
0017 020A     00054      MOVF   ACCB,W      ;MOVE B TO D
0018 002E     00055      MOVWF  ACCD

```

# AN512

```
0019 020B      00056      MOVF      ACCB+1,W
001A 002F      00057      MOVWF     ACCD+1
001B 020C      00058      MOVF      ACCC,W
001C 0030      00059      MOVWF     ACCE
001D 020D      00060      MOVF      ACCC+1,W
001E 0031      00061      MOVWF     ACCE+1
001F 006A      00062      CLRF      ACCB
0020 006B      00063      CLRF      ACCB+1
0021 0800      00064      RETLW     0
                00065
0022 0000      00066      NOP
0023 0915      00067 DIV    CALL      SETUP
0024 0C20      00068      MOVLW     20
0025 0034      00069      MOVWF     TEMP
0026 006C      00070      CLRF      ACCC
0027 006D      00071      CLRF      ACCC+1
0028 0403      00072 DLOOP  CLRF
0029 0371      00073      RLF       ACCE+1, F
002A 0370      00074      RLF       ACCE, f
002B 036F      00075      RLF       ACCD+1, F
002C 036E      00076      RLF       ACCD, F
002D 036D      00077      RLF       ACCC+1, F
002E 036C      00078      RLF       ACCC, F
002F 0208      00079      MOVF      ACCA,W
0030 008C      00080      SUBWF     ACCC,W      ;CHECK IF A>C
0031 0743      00081      SKPZ
0032 0A35      00082      GOTO      NOCHK
0033 0209      00083      MOVF      ACCA+1,W
0034 008D      00084      SUBWF     ACCC+1,W    ;IF MSB EQUAL THEN CHECK LSB
0035 0703      00085 NOCHK  SKPC      ;CARRY SET IF C>A
0036 0A3E      00086      GOTO      NOGO
0037 0209      00087      MOVF      ACCA+1,W    ;C-A INTO C
0038 00AD      00088      SUBWF     ACCC+1, F
0039 0703      00089      BTFSS    3,0
003A 00EC      00090      DECF     ACCC, F
003B 0208      00091      MOVF      ACCA,W
003C 00AC      00092      SUBWF     ACCC, F
003D 0503      00093      SETC      ;SHIFT A 1 INTO B (RESULT)
003E 036B      00094 NOGO  RLF       ACCB+1, F
003F 036A      00095      RLF       ACCB, F
0040 02F4      00096      DECFSZ   TEMP, F      ;LOOP UNTILL ALL BITS CHECKED
0041 0A28      00097      GOTO      DLOOP
0042 0800      00098      RETLW     0
                00099
0043 0C0B      00100 DSCHRG  MOVLW   B'00001011' ;ACTIVATE RA2
0044 0005      00101      TRIS     5
0045 0CFE      00102      MOVLW    0FF
0046 0034      00103      MOVWF    TEMP
0047 02F4      00104 LOOP  DECFSZ  TEMP, F      ;WAIT
0048 0A47      00105      GOTO     LOOP
0049 0C0F      00106      MOVLW   B'00001111' ;ALL OUTPUTS OFF
004A 0005      00107      TRIS     5
004B 0800      00108      RETLW    0
                00109
004C 0061      00110 M_TIME  CLRF      1      ;CLEAR TMR0
004D 0069      00111      CLRF     ACCA+1
004E 0068      00112      CLRF     ACCA
004F 03E9      00113 TLOOP  INCFSZ  ACCA+1, F
0050 0A54      00114      GOTO     ENDCHK
0051 03E8      00115      INCFSZ  ACCA, F
0052 0A54      00116      GOTO     ENDCHK
0053 0A56      00117      GOTO     END_M
0054 0701      00118 ENDCHK  BTFSS    1,0      ;CHECK FOR TMR0 TRIP
0055 0A4F      00119      GOTO     TLOOP
0056 0201      00120 END_M  MOVF      1,W
0057 0800      00121      RETLW    0
```

```

00122
0058 0C03      00123 OHMS  MOVLW  B'00000011'  ;SET RA0 AND RA1 HIGH (ON WHEN ACTIVATED)
0059 0025      00124      MOVWF  5
005A 0C28      00125      MOVLW  B'00101000'  ;SELECT POSITIVE EDGE FOR TMR0
005B 0002      00126      OPTION
00127
005C 0943      00128 CAL   CALL   DSCHRG      ;DISCHARGE CAPACITOR
005D 0C0E      00129      MOVLW  B'00001110'  ;ACTIVATE RA0
005E 0005      00130      TRIS   5
005F 094C      00131      CALL   M_TIME      ;MEASURE TIME
0060 0209      00132      MOVF   ACCA+1,W
0061 0033      00133      MOVWF  TCAL+1      ;STORE LSB
0062 0208      00134      MOVF   ACCA,W
0063 0032      00135      MOVWF  TCAL        ;STORE MSB
00136
0064 0943      00137 MEAS  CALL   DSCHRG      ;DISCHARGE CAPACITOR
0065 0C0D      00138      MOVLW  B'00001101'  ;ACTIVATE RA1
0066 0005      00139      TRIS   5
0067 094C      00140      CALL   M_TIME      ;MEASURE TIME
00141
0068 0C3C      00142      MOVLW  RCALLS      ;CALIBRATION LSB VALUE
0069 002B      00143      MOVWF  ACCB+1
006A 0C2F      00144      MOVLW  RCALMS      ;CALIBRATION MSB VALUE
006B 002A      00145      MOVWF  ACCB
00146
006C 0908      00147      CALL   MPY          ;MULTIPLY ACCA(MEAS) * ACCB(RCAL)
006D 0213      00148      MOVF   TCAL+1,W
006E 0029      00149      MOVWF  ACCA+1
006F 0212      00150      MOVF   TCAL,W
0070 0028      00151      MOVWF  ACCA
00152
0071 0923      00153      CALL   DIV          ;DIVIDE ACCB(MEAS * R) BY ACCA(TCAL)
00154
0072 0A58      00155      GOTO  OHMS
00156
00157      END

```

MEMORY USAGE MAP ('X' = Used, '-' = Unused)

```

0000 : XXXXXXXXXXXXXXXXXXXX XXXXXXXXXXXXXXXXXXXX XXXXXXXXXXXXXXXXXXXX XXXXXXXXXXXXXXXXXXXX
0040 : XXXXXXXXXXXXXXXXXXXX XXXXXXXXXXXXXXXXXXXX XXXXXXXXXXXXXXXXXXXX XXX-----
01C0 : -----X

```

All other memory blocks unused.

```

Program Memory Words Used:  116
Program Memory Words Free:  396

```

```

Errors   : 0
Warnings : 0 reported, 0 suppressed
Messages : 0 reported, 0 suppressed

```

---

---

**Note the following details of the code protection feature on PICmicro® MCUs.**

- The PICmicro family meets the specifications contained in the Microchip Data Sheet.
- Microchip believes that its family of PICmicro microcontrollers is one of the most secure products of its kind on the market today, when used in the intended manner and under normal conditions.
- There are dishonest and possibly illegal methods used to breach the code protection feature. All of these methods, to our knowledge, require using the PICmicro microcontroller in a manner outside the operating specifications contained in the data sheet. The person doing so may be engaged in theft of intellectual property.
- Microchip is willing to work with the customer who is concerned about the integrity of their code.
- Neither Microchip nor any other semiconductor manufacturer can guarantee the security of their code. Code protection does not mean that we are guaranteeing the product as “unbreakable”.
- Code protection is constantly evolving. We at Microchip are committed to continuously improving the code protection features of our product.

If you have any further questions about this matter, please contact the local sales office nearest to you.

---

Information contained in this publication regarding device applications and the like is intended through suggestion only and may be superseded by updates. It is your responsibility to ensure that your application meets with your specifications. No representation or warranty is given and no liability is assumed by Microchip Technology Incorporated with respect to the accuracy or use of such information, or infringement of patents or other intellectual property rights arising from such use or otherwise. Use of Microchip's products as critical components in life support systems is not authorized except with express written approval by Microchip. No licenses are conveyed, implicitly or otherwise, under any intellectual property rights.

#### **Trademarks**

The Microchip name and logo, the Microchip logo, FilterLab, KEELOQ, microID, MPLAB, PIC, PICmicro, PICMASTER, PICSTART, PRO MATE, SEEVAL and The Embedded Control Solutions Company are registered trademarks of Microchip Technology Incorporated in the U.S.A. and other countries.

dsPIC, ECONOMONITOR, FanSense, FlexROM, fuzzyLAB, In-Circuit Serial Programming, ICSP, ICEPIC, microPort, Migratable Memory, MPASM, MPLIB, MPLINK, MPSIM, MXDEV, PICC, PICDEM, PICDEM.net, rPIC, Select Mode and Total Endurance are trademarks of Microchip Technology Incorporated in the U.S.A.

Serialized Quick Turn Programming (SQTP) is a service mark of Microchip Technology Incorporated in the U.S.A.

All other trademarks mentioned herein are property of their respective companies.

© 2002, Microchip Technology Incorporated, Printed in the U.S.A., All Rights Reserved.

 Printed on recycled paper.

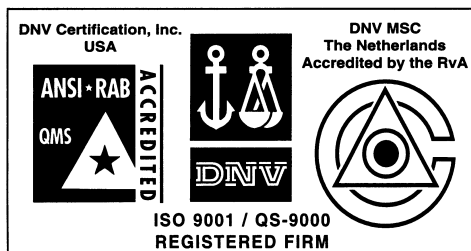

*Microchip received QS-9000 quality system certification for its worldwide headquarters, design and wafer fabrication facilities in Chandler and Tempe, Arizona in July 1999. The Company's quality system processes and procedures are QS-9000 compliant for its PICmicro® 8-bit MCUs, KEELOQ® code hopping devices, Serial EEPROMs and microperipheral products. In addition, Microchip's quality system for the design and manufacture of development systems is ISO 9001 certified.*



# MICROCHIP

## WORLDWIDE SALES AND SERVICE

### AMERICAS

#### Corporate Office

2355 West Chandler Blvd.  
Chandler, AZ 85224-6199  
Tel: 480-792-7200 Fax: 480-792-7277  
Technical Support: 480-792-7627  
Web Address: <http://www.microchip.com>

#### Rocky Mountain

2355 West Chandler Blvd.  
Chandler, AZ 85224-6199  
Tel: 480-792-7966 Fax: 480-792-7456

#### Atlanta

500 Sugar Mill Road, Suite 200B  
Atlanta, GA 30350  
Tel: 770-640-0034 Fax: 770-640-0307

#### Boston

2 Lan Drive, Suite 120  
Westford, MA 01886  
Tel: 978-692-3848 Fax: 978-692-3821

#### Chicago

333 Pierce Road, Suite 180  
Itasca, IL 60143  
Tel: 630-285-0071 Fax: 630-285-0075

#### Dallas

4570 Westgrove Drive, Suite 160  
Addison, TX 75001  
Tel: 972-818-7423 Fax: 972-818-2924

#### Detroit

Tri-Atria Office Building  
32255 Northwestern Highway, Suite 190  
Farmington Hills, MI 48334  
Tel: 248-538-2250 Fax: 248-538-2260

#### Kokomo

2767 S. Albright Road  
Kokomo, Indiana 46902  
Tel: 765-864-8360 Fax: 765-864-8387

#### Los Angeles

18201 Von Karman, Suite 1090  
Irvine, CA 92612  
Tel: 949-263-1888 Fax: 949-263-1338

#### New York

150 Motor Parkway, Suite 202  
Hauppauge, NY 11788  
Tel: 631-273-5305 Fax: 631-273-5335

#### San Jose

Microchip Technology Inc.  
2107 North First Street, Suite 590  
San Jose, CA 95131  
Tel: 408-436-7950 Fax: 408-436-7955

#### Toronto

6285 Northam Drive, Suite 108  
Mississauga, Ontario L4V 1X5, Canada  
Tel: 905-673-0699 Fax: 905-673-6509

### ASIA/PACIFIC

#### Australia

Microchip Technology Australia Pty Ltd  
Suite 22, 41 Rawson Street  
Epping 2121, NSW  
Australia  
Tel: 61-2-9868-6733 Fax: 61-2-9868-6755

#### China - Beijing

Microchip Technology Consulting (Shanghai)  
Co., Ltd., Beijing Liaison Office  
Unit 915  
Bei Hai Wan Tai Bldg.  
No. 6 Chaoyangmen Beidajie  
Beijing, 100027, No. China  
Tel: 86-10-85282100 Fax: 86-10-85282104

#### China - Chengdu

Microchip Technology Consulting (Shanghai)  
Co., Ltd., Chengdu Liaison Office  
Rm. 2401, 24th Floor,  
Ming Xing Financial Tower  
No. 88 TIDU Street  
Chengdu 610016, China  
Tel: 86-28-6766200 Fax: 86-28-6766599

#### China - Fuzhou

Microchip Technology Consulting (Shanghai)  
Co., Ltd., Fuzhou Liaison Office  
Unit 28F, World Trade Plaza  
No. 71 Wusi Road  
Fuzhou 350001, China  
Tel: 86-591-7503506 Fax: 86-591-7503521

#### China - Shanghai

Microchip Technology Consulting (Shanghai)  
Co., Ltd.  
Room 701, Bldg. B  
Far East International Plaza  
No. 317 Xian Xia Road  
Shanghai, 200051  
Tel: 86-21-6275-5700 Fax: 86-21-6275-5060

#### China - Shenzhen

Microchip Technology Consulting (Shanghai)  
Co., Ltd., Shenzhen Liaison Office  
Rm. 1315, 13/F, Shenzhen Kerry Centre,  
Renminnan Lu  
Shenzhen 518001, China  
Tel: 86-755-2350361 Fax: 86-755-2366086

#### Hong Kong

Microchip Technology Hongkong Ltd.  
Unit 901-6, Tower 2, Metroplaza  
223 Hing Fong Road  
Kwai Fong, N.T., Hong Kong  
Tel: 852-2401-1200 Fax: 852-2401-3431

#### India

Microchip Technology Inc.  
India Liaison Office  
Divyasree Chambers  
1 Floor, Wing A (A3/A4)  
No. 11, O'Shaugnessey Road  
Bangalore, 560 025, India  
Tel: 91-80-2290061 Fax: 91-80-2290062

### Japan

Microchip Technology Japan K.K.  
Benex S-1 6F  
3-18-20, Shinyokohama  
Kohoku-Ku, Yokohama-shi  
Kanagawa, 222-0033, Japan  
Tel: 81-45-471- 6166 Fax: 81-45-471-6122

### Korea

Microchip Technology Korea  
168-1, Youngbo Bldg. 3 Floor  
Samsung-Dong, Kangnam-Ku  
Seoul, Korea 135-882  
Tel: 82-2-554-7200 Fax: 82-2-558-5934

### Singapore

Microchip Technology Singapore Pte Ltd.  
200 Middle Road  
#07-02 Prime Centre  
Singapore, 188980  
Tel: 65-6334-8870 Fax: 65-6334-8850

### Taiwan

Microchip Technology Taiwan  
11F-3, No. 207  
Tung Hua North Road  
Taipei, 105, Taiwan  
Tel: 886-2-2717-7175 Fax: 886-2-2545-0139

### EUROPE

#### Denmark

Microchip Technology Nordic ApS  
Regus Business Centre  
Lautrup høj 1-3  
Ballerup DK-2750 Denmark  
Tel: 45 4420 9895 Fax: 45 4420 9910

#### France

Microchip Technology SARL  
Parc d'Activite du Moulin de Massy  
43 Rue du Saule Trapu  
Batiment A - 1er Etage  
91300 Massy, France  
Tel: 33-1-69-53-63-20 Fax: 33-1-69-30-90-79

#### Germany

Microchip Technology GmbH  
Gustav-Heinemann Ring 125  
D-81739 Munich, Germany  
Tel: 49-89-627-144 0 Fax: 49-89-627-144-44

#### Italy

Microchip Technology SRL  
Centro Direzionale Colleoni  
Palazzo Taurus 1 V. Le Colleoni 1  
20041 Agrate Brianza  
Milan, Italy  
Tel: 39-039-65791-1 Fax: 39-039-6899883

#### United Kingdom

Arizona Microchip Technology Ltd.  
505 Eskdale Road  
Winnersh Triangle  
Wokingham  
Berkshire, England RG41 5TU  
Tel: 44 118 921 5869 Fax: 44-118 921-5820

03/01/02