

# WASTE WATER FROM FIBREBOARD MILLS

G. GRAN

*Defibrator AB, P.O. Box 27073, 10251 Stockholm 27*

## ABSTRACT

Information about waste water from the manufacture of fibreboard is given, and in this connection a classification of suspended and dissolved impurities occurring in the waste water of fibreboard mills is made. The influence on the concentration and the total amount of such impurities are discussed as a function of the extent of closing of the process water system. Various methods of treatment are reported and methods for obtaining small quantities of waste water with a correspondingly high concentration of impurities are discussed. Further, the possibilities of eliminating the impurities by evaporation of the waste water and burning of the evaporation concentrate are discussed. In this connection other possibilities of eliminating the impurities are mentioned, e.g. treatment by the activated sludge method, flocculation, fodder yeast manufacture, etc.

---

## INTRODUCTION

Plants belonging to the forestry industries are generally considered as being among the severest water-polluting industrial units. The plants producing cellulose, especially the kraft pulp mills, are nowadays generally very big units with production capacities of several hundred thousand tons per year. The kraft mills solved their waste water problem long ago—at least in principle—as they recover the cooking chemicals by evaporating and burning the black liquor, although these methods could be further refined in order to avoid air pollution and the still remaining water pollution. The untreated effluents from sulphite pulp mills cause considerable water pollution, and nowadays many of them also evaporate and burn their waste liquors. The introduction of sodium, magnesium and ammonia as base instead of calcium has made this recovery of the cooking chemicals both necessary and possible from an economical standpoint.

In the fibreboard industry there were no cooking chemicals to recover. Thus, until recently little was done about the waste water problem. Most fibreboard mills had a capacity of 20 000–50 000 tons per year and the polluting substances were dissolved in fairly large volumes of effluent. For these reasons there was little economical incentive for taking any radical steps towards an efficient waste water control. Today most fibreboard mills have to face the fact that, due to legislation, they must do something about their waste water in the near future.

## THE FIBREBOARD INDUSTRY AS A WATER POLLUTER

Figure 1 shows the magnitude of the pollution caused by the fibreboard industry in comparison with other forestry industries, where a considerable part of the raw material goes into solution during the manufacturing process. It is the dissolution of part of the wood substance that makes these industries so strongly polluting in comparison with groundwood mills, for example, where only a mechanical treatment of the wood takes place.

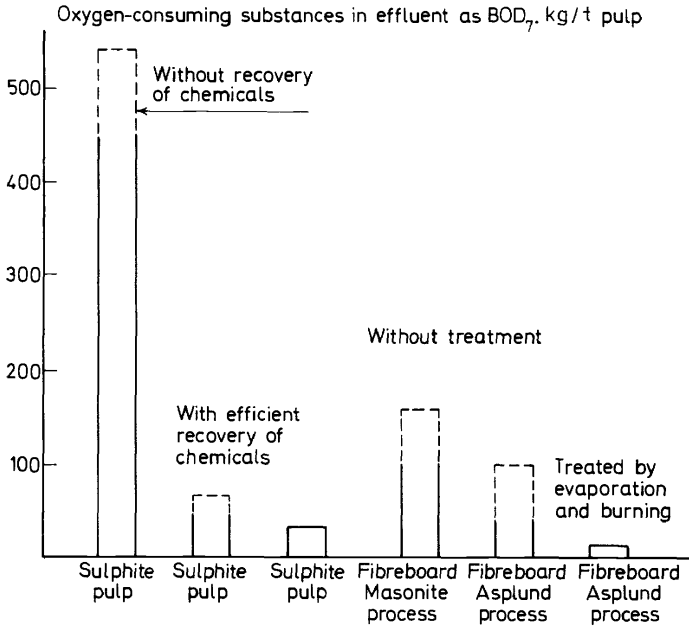

Figure 1. Amount of oxygen-consuming substance left in the effluent from various forestry industries

The height of the rectangles indicates the amount of BOD<sub>7</sub>, expressed as kg/t product, which is left in the effluent.

The fibreboard industry is seen to produce the same amount of polluting substances as most of the other forestry industries per ton of product produced. On average, however, the fibreboard mills are much smaller production units than the pulp mills and would for that reason cause less pollution. Unfortunately many fibreboard mills are situated on very small rivers, where the flow of water may be extremely small during part of the year. Sweden's biggest fibreboard mill is situated on a river which has an extreme minimum flow of only 0.3 m<sup>3</sup>/s. With a production of more than 400 t/24 h this would mean a flow of less than 65 m<sup>3</sup>/t. With a BOD load close to 50 kg/t this would mean a BOD load on the river water of roughly 750 mg/l, if no arrangements were made for reducing the amount of pollutants. It is thus of great importance to look at the pollution problem with due regard to the capacity of the receiving river or stream.

WASTE WATER FROM FIBREBOARD MILLS  
**POLLUTANTS IN THE WASTE WATER**

The impurities occurring in the waste water of fibreboard mills may be placed in the following five categories: (1) fibres; (2) cell fragments, e.g. particles of bark or parenchymous cells, either intact or fragmented; (3) colloidal organic substances which come from the wood; (4) soluble organic substances released from the wood; (5) soluble and insoluble chemicals added during the manufacture of the fibreboard, e.g. alum, paraffin, fungicides, synthetic resins.

The concentration of these substances in the waste water depends on several circumstances, e.g. the type of wood or other raw material, the pre-heating conditions and the extent to which the process water system of the mill is closed. However, the following figures may be considered as fairly normal limits for the concentration: (i) fibres, 25 to 250 mg/l, defined as suspended solids in the waste water caught on a 240 mesh wire screen; (ii) cell fragments and other suspended substances, 100 to 3000 mg/l, defined as solids passing a 240 mesh screen but caught on a filter paper; (iii) colloidal and dissolved substances, 500 to 10000 mg/l, defined as the total amount of evaporation residue in the filtered waste water (for rough calculation 1 kg of these substances corresponds to 0.6 to 0.7 kg BOD<sub>5</sub> or 0.7 to 0.8 kg BOD<sub>7</sub>).

**DISSOLUTION OF THE WOOD SUBSTANCES**

The dissolution of the wood substances takes place mainly during the pre-heating and defibration process and is closely related to the kind of raw material used. It is also a function of the pre-heating temperature and the pre-heating time.

It is rather difficult to determine the yield of pulp from wood as a function of the pre-heating conditions as, in general, the pre-heating periods used in practice are fairly short in comparison to the time it takes for the chips to reach the final temperature in the pre-heater. Some attempts have been made, however, and two sets of curves are shown in *Figure 2* and *Figure 3*.

In *Figure 2* the pulp yield from birch is shown as a function of the pre-heating time at three temperatures. The determinations were made with water as 'cooking liquor' in connection with investigations on semi-chemical pulping, which is the reason why the pre-heating time was extended to 60 minutes.

In *Figure 3* a similar graph for beech wood is shown, where the pre-heating period was extended to 16 minutes only. In both diagrams it is clearly shown that the dissolution proceeds much faster as the pre-heating temperature is increased.

During the pre-heating period two main reactions take place. One of them is the hydrolysis of hemicellulose molecules, whereby oligosaccharides are formed. These short-chain molecules are small enough to dissolve in water. The other reaction is the hydrolysis of acetyl groups, whereby acetic acid is formed, causing an increase in the hydrogen ion concentration in the raw material. The higher acidity causes the hydrolytic reactions to proceed still faster. Thus the reactions can be said to be autocatalytic. For that reason it is very difficult to calculate rates of reaction for the dissolution of wood

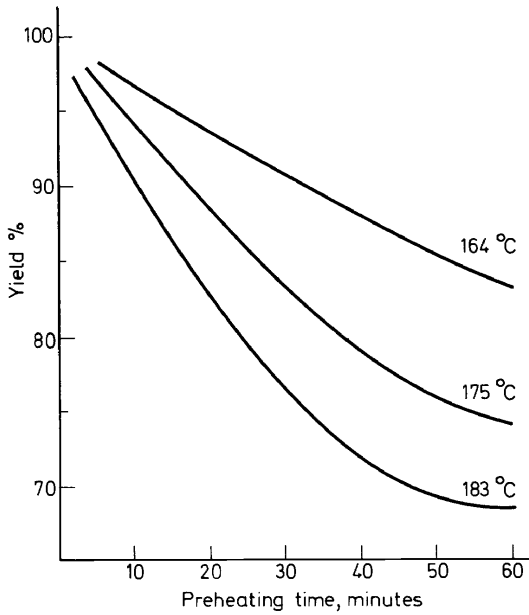

Figure 2. Pulp yield as a function of the pre-heating time at three temperatures using birch as the raw material

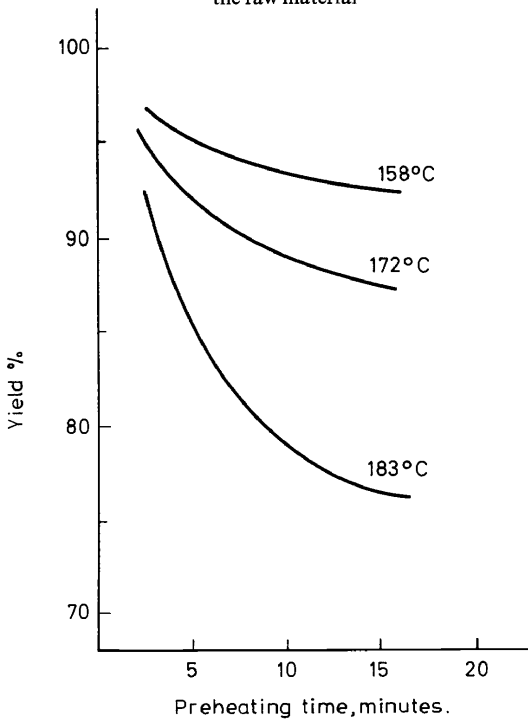

Figure 3. Pulp yield as a function of the pre-heating time at three temperatures using beech as the raw material

substances during the pre-heating stage. As a rough estimation, however, the rate of reaction seems to double at an increase in temperature of about 8°C, which is a normal value for most chemical reactions.

It does not seem possible with all raw materials to compensate, for example, a lower pre-heating temperature by a correspondingly longer pre-heating period. This is probably due to the influence on the pulp properties of the mechanical treatment of the raw material during the defibration, as the softening of the raw material, for example, will be more pronounced at higher temperatures.

The idea behind the use of a pre-heater before the grinding discs of the Defibrator is the softening effect caused by the high temperature on the substances which hold the individual fibres together in the lignocellulosic raw material. The dissolution of some of the carbohydrates during the pre-heating stage also tends to weaken the bonds between the fibres. For these reasons much less energy is needed for the defibration of wood chips which have been pre-heated than for the defibration of chips without pre-heating as in the refiner groundwood process.

In many cases it seems that strong pre-heating tends to give a board with better dimensional stability. This tendency was especially marked in the Masonite process, where the amount of wood substances dissolved could sometimes be two to three times the amount dissolved in the Asplund-Defibrator process when the same raw material was used.

With increasing costs for waste water treatment due to high BOD loads in the waste water, suggestions have been made to decrease the BOD load by making the pre-heating stage much milder at the expense of higher energy consumption for the defibration. Thorough investigations have not yet been made in this direction and it should be pointed out that only part of the BOD load can be eliminated in this way. It will also be necessary to investigate the influence of mild pre-heating on the physical and mechanical properties of the fibreboard, especially the dimensional stability.

### COMPOSITION OF DISSOLVED WOOD SUBSTANCES

So far no exhaustive investigations seem to have been made on the composition of the substances dissolved during the pre-heating and defibration steps. An examination of the composition of the substances dissolved in the Masonite process was made by Edhborg some fifteen years ago. The temperature in the Asplund-Defibrator process is normally about 180°C and the pre-heating time usually from one up to a few minutes. The temperature in the Masonite process, on the other hand, is increased to between 250 and 300°C, even if it is only for a few seconds. This leads to greater amounts of substances being dissolved in the latter process and also to more acidic conditions—a pH value of about 3 was obtained in an extract from a Masonite pulp whereas the pH values in extracts from Defibrator pulps are usually close to 4. The acidity depends partly on volatile acids like acetic and formic acid and partly on non-volatile ones, among which uronic acid is the most frequent.

The investigation on dissolved substances in the Masonite process was based on coniferous wood as raw material. The dissolved substances in this

case consisted of about 70 per cent carbohydrates, 10 per cent lignin—partly modified—and 20 per cent 'organic resins'. The carbohydrates consisted of 35 per cent pentosans, mostly xylans, and 65 per cent hexosans.

Corresponding investigations on dissolved substances in the Asplund-Defibrator process were made with beech as raw material. In this case 75 per cent of the dissolved substances were carbohydrates and a few per cent were lignin-type substances. In addition about 10 per cent acetic acid, partly free and partly bound as acetyl groups, was found. In this case about 80 per cent of the carbohydrates were pentosans, mainly xylans, and 20 per cent hexosans.

### WATER BALANCE OF THE FIBREBOARD PROCESS

Fibreboard production by the Asplund-Defibrator process seen from the point of view of water pollution may be illustrated by the greatly simplified scheme in *Figure 4*, which shows the points where appreciable amounts of water enter or leave the system.

Water enters: (1) with the raw material, which in most cases contains about 50 per cent moisture; (2) as steam condensate in the pre-heater; (3) for dilution of the pulp at various points in the process; (4) with the sizing chemicals; (5) as spray water for cleaning the wire screens of the wet forming machine; (6) as sealing water in the packing boxes of the Defibrators, Raffinators, pumps and agitators; (7) as sealing water for the vacuum pumps; (8) as steam and water in the humidifying chambers or humidifying machines.

Water leaves the system: (1) at the screw feeder to the Defibrator; (2) as steam from the cyclone after the Defibrator; (3) at the wet forming machine—table rolls, suction boxes and roller presses; (4) as sealing water from the vacuum pumps; (5) as strongly polluted water in the hot press; (6) as steam in the hot press; (7) as steam in small amounts in the heat treatment chambers.

Strongly polluted waters leaving the system are numbers (1), (3), and (5). In many modern fibreboard mills chip washing equipment is also installed, from which strongly polluted water leaves the process.

### CLOSING OF THE PROCESS WATER SYSTEM

By closing the process water system in a fibreboard mill it is possible to influence the pollution caused by fibres and other suspended substances. As a first approximation these substances have about the same concentration in the waste water almost independently of the total volume of waste water per ton of fibreboard. The total discharge of fibres and suspended substances will thus be roughly proportionate to the volume of waste water.

The total amount of soluble substances in the waste water, on the other hand, is not influenced very much by a moderate closing of the process water system. As can be seen in *Figure 5*, a reduction of the volume of waste water from 50 to 10 m<sup>3</sup>/t of board produced will only decrease the total discharge of soluble substances by about 8 per cent—from 98 per cent to about 90 per cent of the total amount of soluble substances; the 2 or 10 per cent will stay in the board sheets, as it is dissolved in the water which is evaporated in the hot press.

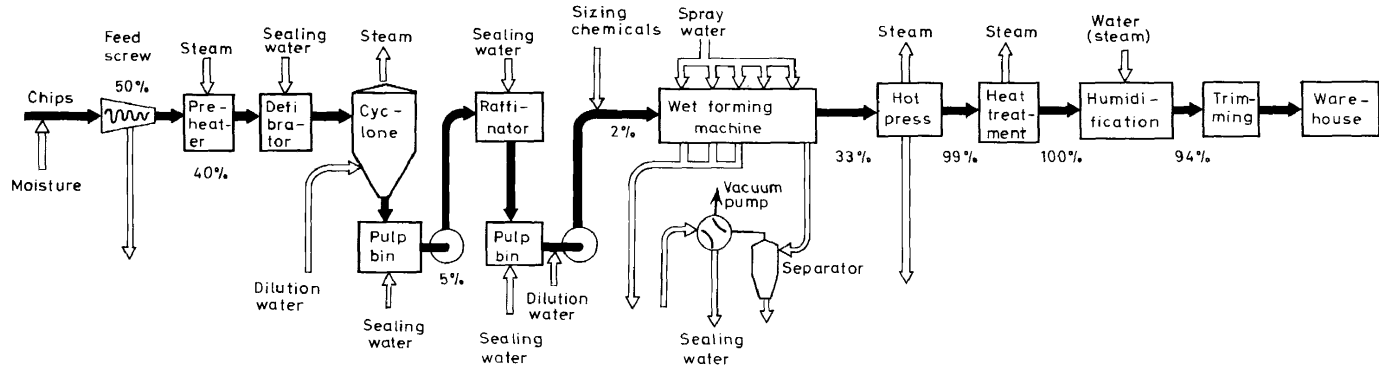
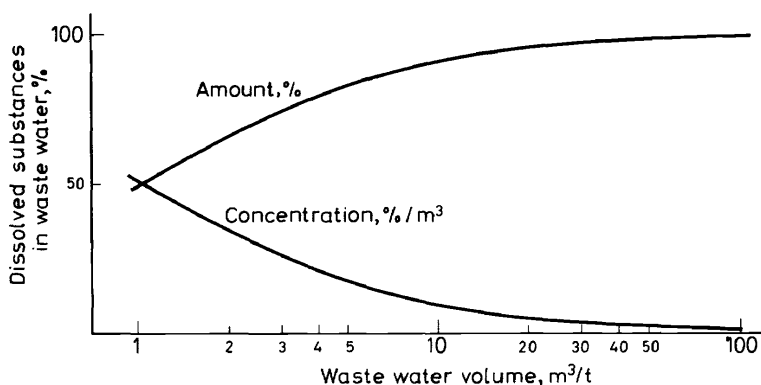

Figure 4. Water entering and leaving the system during fibreboard manufacture by the Asplund-Defibrator process

In this case a reduction of the volume of waste water results mainly in a corresponding increase in the concentration of the dissolved substances, as can also be seen in *Figure 5*.

Only when the process water system can be nearly completely closed can the discharge of soluble substances be reduced by any appreciable degree. In the Swedish mill mentioned previously, the process water system has been closed to 1.5–2 m<sup>3</sup>/t, which, according to *Figure 5*, leads to a reduction in the



*Figure 5.* Percentage of dissolved substances leaving the system with the waste water and their concentration

amount of soluble substances discharged with the waste water to 60–65 per cent; in this case 35–40 per cent of the dissolved wood substances are retained in the board.

The more the process water system is closed the higher its temperature becomes. In highly closed systems some kind of cooling of the circulating process water may be necessary. In a plant where a trial was made to close the process water system to less than 3 m<sup>3</sup>/t, the temperature of the system rose to close to 80°C. This caused, among other things, certain corrosion problems and difficulties in some bins, which were not designed for temperatures as high as 80°C. Further it was also unpleasant for the personnel to work under the very humid conditions prevailing in the neighbourhood of the wet forming machine.

A closing of the process water system which is too extensive may also cause certain difficulties in the manufacturing process. Due to the increased concentration of soluble substances, there will be a greater risk for spot formation on the board sheets and for sticking in the hot press. Such difficulties may be overcome, e.g. by washing the surface plates more often or by using release agents such as especially designed paraffin emulsions or by lowering the temperature of the hot press. Such precautions may, however, reduce the production or cost extra money. These trends seem to be more pronounced with hardwood as raw material than with softwood.



## WASTE WATER FROM FIBREBOARD MILLS

### EXTRACTION OF CONCENTRATED WASTE WATER

A very simplified illustration of the path followed by the water in a fibreboard mill with a partially closed process water system is given in *Figure 6*. The process water is recirculated in many more ways than are shown in the scheme but this is insignificant as regards the net result with respect to the

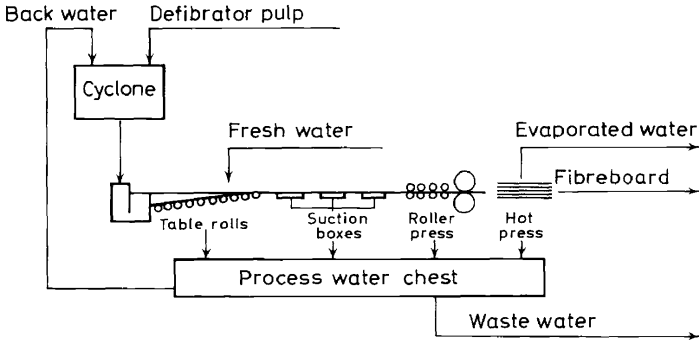

*Figure 6.* Simplified water flow scheme in a fibreboard mill with a partially closed process water system

concentration of soluble substances in the waste water. This concentration is thus a function of the volume of process waste water as given in *Figure 5*.

When it is desirable to decrease the volume of waste water without increasing the concentration of soluble substances in the process water system at the same time, it is possible to arrange some kind of washing of the pulp before it enters the main process line. An arrangement of this type is shown in *Figure 7*, where a dewatering press has been inserted after the cyclone. If the

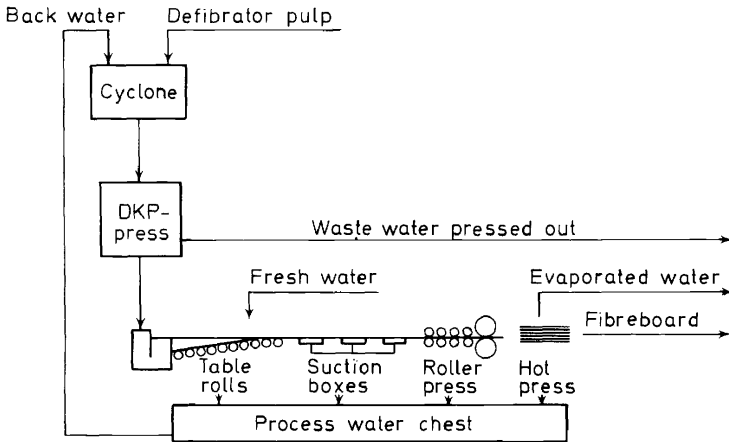

*Figure 7.* Simplified water flow scheme in a fibreboard mill with a press for washing the pulp; the process water system is completely closed except for the concentrated waste water leaving the press

process water system is completely closed, all soluble substances with the exception of those deposited in the fibreboard would be contained in the waste water leaving the press. The concentration of soluble substances in this waste water depends on the amount of substances dissolved during the pre-heating, on the volume of waste water leaving the press and finally on the efficiency of the press, i.e. the consistency of the pulp leaving the press. The efficiency of such a system can be increased by installing two or three presses in series. Of course, the same goal can be reached by using a number of filters as in the pulp washing systems of kraft mills, for example, but it seems that for this purpose presses are the most efficient and space-saving type of equipment.

It should perhaps be stressed at this point that the installation of a press will not increase the concentration of soluble substances in the waste water leaving the press by more than about 20 per cent in comparison with the concentration of a process water system closed to the same degree without the installation of a press. The important advantage gained when a press is installed is that the concentration of soluble substances in the recirculated process water will be much lower than without a press for the same volume of waste water.

Figure 8 shows how many cubic metres of waste water must be pressed out per ton of pulp in order to obtain the same concentration of soluble-substances in the recirculating process water when one, two or three presses are

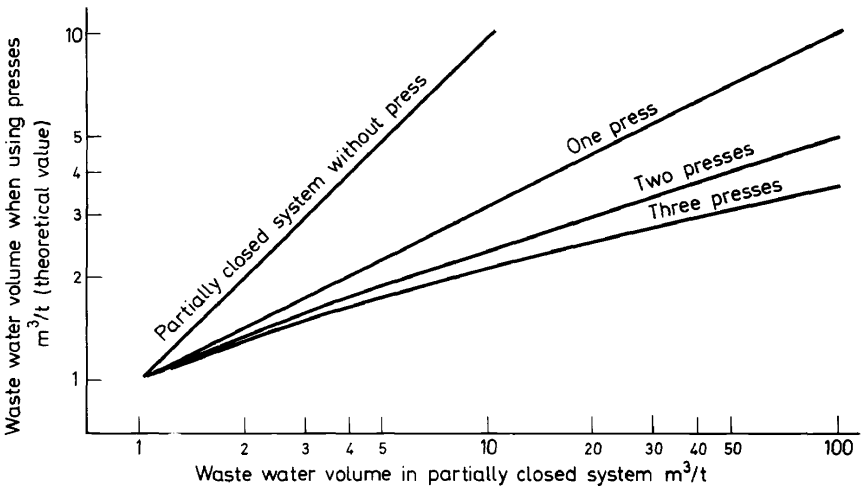

Figure 8. Amount of waste water with and without the use of dewatering presses

used in series as in a partially closed system without presses. It is assumed that the pulp concentration after the press is about 50 per cent. If a concentration in the process water system corresponding to 20 m<sup>3</sup>/t of waste water in a partially closed system is desired, this can be obtained by taking out 4.5 m<sup>3</sup>/t waste water with one press, 3 m<sup>3</sup>/t waste water with two presses and 2.5 m<sup>3</sup>/t waste water with three presses. The installation of presses thus makes it

## WASTE WATER FROM FIBREBOARD MILLS

possible to reduce the volume of waste water without increasing the risk of spots or sticking in the hot press due to the high concentration of soluble substances in the process water.

The presses mentioned are of the conical disc type. They are shown in *Figures 9 and 10*. The pulp slurry at a concentration of 12–15 per cent enters the press where the distance between the conical discs is greatest. When the

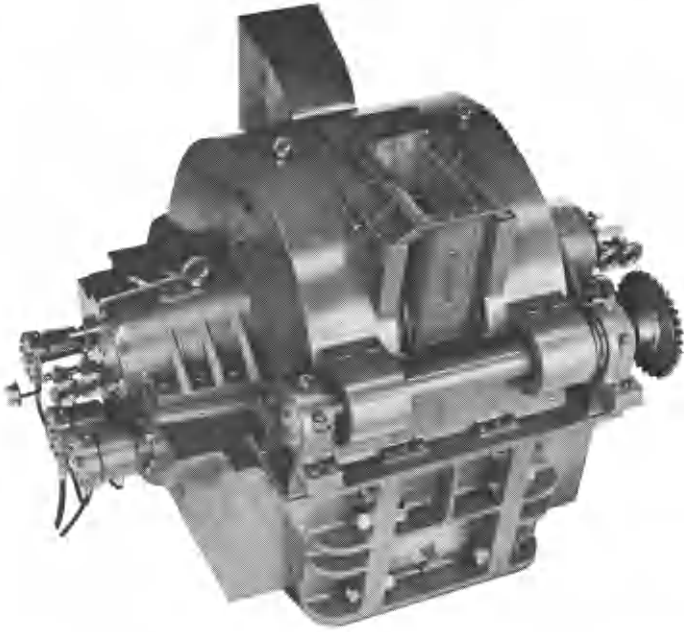

*Figure 9.* Dewatering press DKP

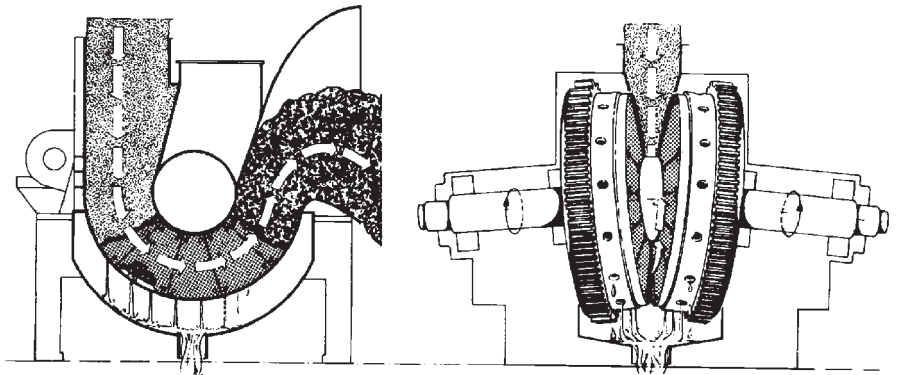

Conical dewatering press type DKP

Defibrator AB Stockholm Sweden

*Figure 10.* Working principle of the dewatering press DKP

discs rotate the distance between them decreases and the pulp slurry is exposed to an uninterrupted compression. The water which is squeezed out penetrates the discs through perforations in the disc plates. Thus the pulp is neither kneaded nor sheared during the pressing, which ensures that it can be dissolved without difficulty after the press.

The presses are constructed and manufactured by Defibrator AB and are called Davenport and DKP presses respectively. Their capacity is between 100 and 150 t/24 h and the concentration of the pulp leaving the presses is 35 to 50 per cent, the lower figures being related to the Davenport press and the higher ones to the DKP press. The consistency of the pulp leaving the presses depends to some extent on the degree to which the rated capacity of the press is exploited. When the presses operate at low speed and thus at a low production, the water can of course be squeezed out more effectively.

### REDUCTION OF SUSPENDED SOLIDS

Much can be done in a board mill to reduce the amount of suspended solids which are discharged with the waste water. As mentioned earlier the total amount of solids discharged can be very much reduced by closing the process water system. Twenty years ago many fibreboard mills used more or less open systems and the water consumption was 50 to 100 m<sup>3</sup>/t.

Today a water consumption of 20–30 m<sup>3</sup>/t is quite normal and in many mills the amount of process waste water is much less due to a partially closed system and to sectioning of the water flow in the mill into several flow systems according to the amount and character of the pollutants in them. These measures are often combined with installations of filters or sedimentation basins; flotation does not seem to be used to any appreciable degree within the fibreboard industry.

In a Swedish fibreboard mill the waste water flow has been sectioned in the following way:

- (1) Excess process water is filtered and pumped to an evaporation plant, where
  - (a) the concentrate at 36–40 per cent concentration is burnt in the steam boiler.
  - (b) the condensate is discharged without further treatment into the recipient.
 The process water system is extremely closed and has a very high BOD value.
- (2) Waste waters containing fibre and sludge, e.g. from spraying the wire screens of the wet forming machine and from the plate washing, are conducted to a sedimentation pond.
- (3) Practically unpolluted waste waters, e.g. rain water, cooling water and some sealing water, are discharged into the recipient without any treatment at all.
- (4) Sanitary sewage is discharged into the municipal sewage system to be treated in the biological—activated sludge—treatment plant.

In this way roughly 90 per cent of the total BOD load has been eliminated. The present water flow of this factory is illustrated in *Figure 11*. This mill is using mainly softwood as raw material and has been able to close its process

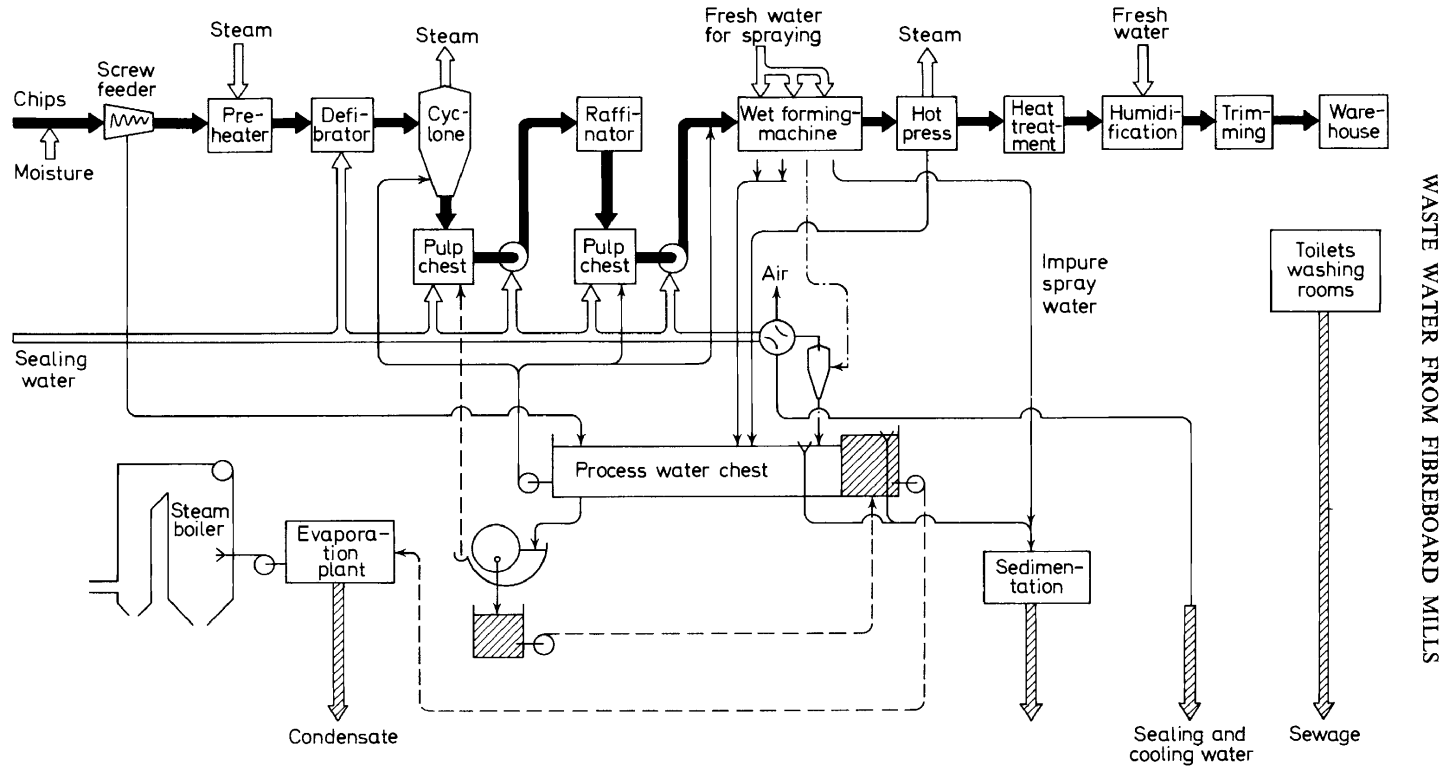

Figure 11. Sectioned water flow in a Swedish fibreboard mill

water system to a very high degree without using presses. The difficulties encountered in the hot press in the beginning have been overcome.

The filters used in fibreboard mills are of two types. For the filtration and recovery of rather coarse particles, e.g. in the chip washing plant and in the water coming from the screw feeder, an ordinary drum filter covered with a wire screen is used. The filters used for filtration of process water and waste water often work with a filtering aid consisting of a pulp mat which is later returned to the production line together with the fines and other suspended solids filtered out.

The efficiency of such filters varies markedly depending on different production parameters. The following figures obtained from mills using various types of filter can be given as examples.

Mill	Suspended solids, mg/l	
	Before the filter	After the filter
A	1 000–3 500	80–250
B	170–1 000	30–150
C	1 000–1 300	280–330
D	230– 620	90–145

The mechanical waste water treatment is sometimes finished by sedimentation. Due to local circumstances the sedimentation basins vary very much with regard to construction form and size. As a general rule the surface load should not exceed about 1 m/h and the depth of the basin should be about 2 m. Efficiency figures are scarce but a Swedish mill reports a content of suspended solids of 20–70 mg/l in the waste water leaving the sedimentation basin. An average value of 45 mg/l is reported.

Both filtration and sedimentation will give a treated water which is clear enough to be returned and used, for example, in some types of spray nozzles where a fairly high quality of water is needed. The content of suspended solids seems to be too high, however, to allow the re-use of such waters as sealing water in packing boxes. As a certain volume of water is always needed for this purpose, this has meant a certain minimum flow of fresh water into the process water system.

From this point of view a new method, recently developed in Finland at the Savo Oy mill, for the treatment of waste water might be of interest. This method may be called activated flocculation. It includes a chemical treatment of the waste water followed by sedimentation or flotation. The chemical treatment includes adjustment of the pH-value, addition of chemicals for precipitation and coagulation of suspended solids and some dissolved or colloidal substances, and finally a readjustment of the pH-value in order to complete the precipitation and coagulation.

After this treatment the waste water enters a small basin where the coagulated flocs either sink to the bottom or float to the surface. At the outlet end of the basin the flocs are removed either by surface overflow in the case of flotation or by a bottom screw and drain pipe in the case of sedimentation. While a very clear and light-coloured water is obtained through a throttled

## WASTE WATER FROM FIBREBOARD MILLS

drain pipe halfway between the bottom and the surface. This treated water is so clear that it seems possible to use it as sealing water, at least for some purposes, e.g. for agitators and some pumps. Such an arrangement would make it possible to close the process water system still more in cases where unavoidable use of fresh water limits the possibilities of closing the system any further.

The flocs which are separated by sedimentation or flotation are pumped back to the production line, preferably to the machine chest. The chemicals used for coagulation influence the properties in much the same way as the normal sizing chemicals, and at the Savo Oy mill no other chemicals are now used for sizing than those added in the waste water treatment process.

At the Savo mill it has been possible to reduce the amount of BOD<sub>5</sub> from about 12 000 kg/24 h to about 4 000 kg/24 h. Of these amounts, however, about 900 kg/24 h are not passing the treatment plant. Thus the BOD reduction in the treated waste water is over 70 per cent, and experiments—not yet proved in practice—indicate that it will be possible to achieve a BOD reduction of 80 per cent or even more.

## WASTE WATER DISPOSAL

Most existing fibreboard mills are situated in places where it was and in most cases still is possible to dispose of the waste water by discharging it into a nearby river. In recent years, however, an ever-increasing number of these mills find that they will soon have to face regulations with regard to water pollution which make it necessary to make arrangements for decreasing the outlets.

## PONDING

Sometimes it may be possible to dispose of the waste water by discharging it into a nearby river most of the time. However, for some months the water flow in the river may be quite low, which would make it impossible to let out the full volume of waste water during that season. In such cases the waste water may be retained for some time in ponds from which it can be released under controlled conditions when the water flow in the river is high enough to permit an outlet again. A production line of 100 t/24 h requires a pond volume of 50–75,000 m<sup>3</sup> for every month that the waste water has to be retained in the ponds. It may be mentioned here that, according to a recent publication, the Masonite plant at Laurel, Miss., U.S.A. has holding ponds covering an area of almost 100 hectares and with a total volume of almost 3 000 000 m<sup>3</sup>.

## IRRIGATION

In countries with a warm and dry climate, land irrigation by the waste water after proper pretreatment may be a suitable solution to the disposal problem.

In some cases most of the waste water will be evaporated from the irrigated areas, and in other cases most of the waste water will penetrate the uppermost

soil layer. Colloids and dissolved substances are in this case adsorbed on to the soil surface and attacked by a variety of micro-organisms inhabiting the soil and vegetation which break down the organic substances in the waste water.

Before the waste water can be used for irrigation suspended solids should be removed as far as possible, especially in cases of spraying in order not to clog the spray nozzles, the pH-value should be increased to within 6.0–9.5, and the temperature should be reduced to a value not exceeding 50°C. In most cases the sodium absorption ratio should be adjusted to a value below 8, at least on permeable soils. The sodium absorption ration (SAR) is defined by the formula

$$\text{SAR} = C_{\text{Na}^+} / (C_{\text{Ca}^{2+}} + C_{\text{Mg}^{2+}})^{\frac{1}{2}}$$

where the concentrations (C) are expressed in milliequivalents per litre. In case where the sodium concentration is too high ion exchange may take place whereby calcium and magnesium ions are replaced by sodium ions resulting in deflocculation of the soil (especially clay) and decreased permeability in both air and water. Usually, a low enough sodium absorption ratio can be obtained if the pH value of the waste water is increased by the use of lime.

The irrigation method has the advantages of being fairly simple to operate and of having moderate operating cost. On the other hand, there are also some disadvantages, such as the requirement for large areas of land, detailed knowledge and continuous checking of the subsurface conditions, and possible contamination of subsurface water supplies—ground water, wells, streams and lakes. Further, the method is restricted to warm and dry areas as rainy weather reduces the useful area owing to surface drainage and/or reduced evaporation.

As irrigation conditions change with the time of the year, an irrigation system has to be combined with holding ponds for the waste water during seasons when only small amounts of waste water can be used for irrigation, e.g. cold and/or rainy periods.

### BIOLOGICAL TREATMENT

A few fibreboard mills have adopted the activated sludge method for reducing the amount of dissolved oxygen-consuming substances in their waste water. Normally the waste water passes a sand trap, a primary settling tank, aeration basins and a secondary settling tank. Before the waste water enters the aeration basins nutrients are added and the pH-value is regulated. In most cases one part of phosphorous and five parts of nitrogen per 100 parts of BOD<sub>5</sub> must be added in order to obtain a sufficiently high efficiency in the aeration step. Nitrogen can be added as ammonia, ammonium salts or nitrates and phosphorus as phosphoric acid or phosphates, e.g. superphosphate. Usually some anti-foaming agent is added at the same time. The pH-value can be controlled either by choosing suitable nutrients or by adding pH-controlling chemicals, e.g. sodium hydroxide.

The main operating costs are for chemicals (nutrients) and for power. Of the power consumption, 60 to 70 per cent is normally used for aeration. The BOD reduction values which can be obtained vary between 70 and 90



## WASTE WATER FROM FIBREBOARD MILLS

per cent. Probably values between 75 and 85 per cent are reasonable. Higher values seem to be the result of extremely long detention time in the aeration basins with an accordingly high consumption of air.

The activated sludge method has the advantage of not requiring a very closed process water system in the fibreboard mill. In fact, a too concentrated waste water requires dilution in order to obtain satisfactory operation of the secondary settling tank.

The disadvantages of the biological treatment seem to be the relatively high cost, the danger of releasing nutrients, especially phosphorus, with the effluent from the activated sludge plant into the recipient, and the problem of the excess sludge which has to be disposed of in some way.

Approximately 2 to 3 tons (dry basis) of excess sludge is obtained per 100 tons of fibreboard produced. As this sludge after settling will reach a concentration of only 0.5 to 2.0 per cent, even a fibreboard mill of very moderate size would have a problem to dispose of 100 to 500 m<sup>3</sup> of excess sludge per day. In one or two mills at least the excess sludge is pumped back into the fibreboard mill and mixed with the fibre in a suitable chest, usually the chest after the Raffinators or the machine chest.

The addition of the sludge to the fibre increases the water absorption of the fibreboard produced in the mill. In order to keep the water absorption at an acceptable level, the addition of aluminium sulphate has to be increased and it may also be necessary to add phenolic resin or to increase the addition of it.

The use of phenolic resin may cause a small but measurable concentration of phenol in the waste water. A fibreboard mill has reported a concentration of 3.1 ppm phenol in the waste water and 0.7 ppm in the effluent from the activated sludge plant, corresponding to a reduction in the phenol concentration of 75 to 80 per cent. In the actual mill that corresponded to a phenol concentration in the recipient at the point of discharge and after mixing of almost 0.05 ppm.

In recent years much work has been done on the disposal of excess sludge. Through the addition of various chemicals some kind of coagulation is aimed at in order to obtain a sludge of higher concentration which can be further increased through mechanical treatment, e.g. centrifugation, filtration or pressing. In such cases the excess activated sludge is often treated in combination with primary sludge or some other refuse of a fibrous or similar structure. The ultimate goal should most probably be a treatment of the excess sludge to increase its concentration to such a level that it can be dried and burnt economically.

The release of nutrients, especially phosphorus, into the recipient can be decreased by installing and running a third stage equipment for phosphate precipitation, which will, however, involve further cost.

It seems that in recent years some positive results have been obtained in applying the bacterial bed technique to the treatment of waste water from fibreboard plants.

## AERATED BASINS

For many types of waste water aerated basins have been tried both with

and without the addition of nutrients. With nutrients the disadvantage of discharging them together with the waste water into the ultimate recipient always exists. Very little seems to have been done in this field for the fibre-board industry, however.

An aerated basin sometimes seems to be a suitable complement to a biological treatment in order to decrease the remaining BOD and to increase the concentration of dissolved oxygen in the effluent.

## EVAPORATION

A very interesting method of eliminating the oxygen-consuming substances is the evaporation of the waste water and the burning of the concentrate. The concentrate may also be used as cattle feed.

A prerequisite for using this method is a very low specific volume of waste water, as even very modern and efficient evaporators require about 0.25 ton of steam for every ton of water evaporated. Thus the process water system must be very closed and/or a press may have to be installed in order to obtain the low specific volume required.

A big Swedish fibreboard mill has been using evaporation for about five years. The mill has closed its process water system to a volume of only about

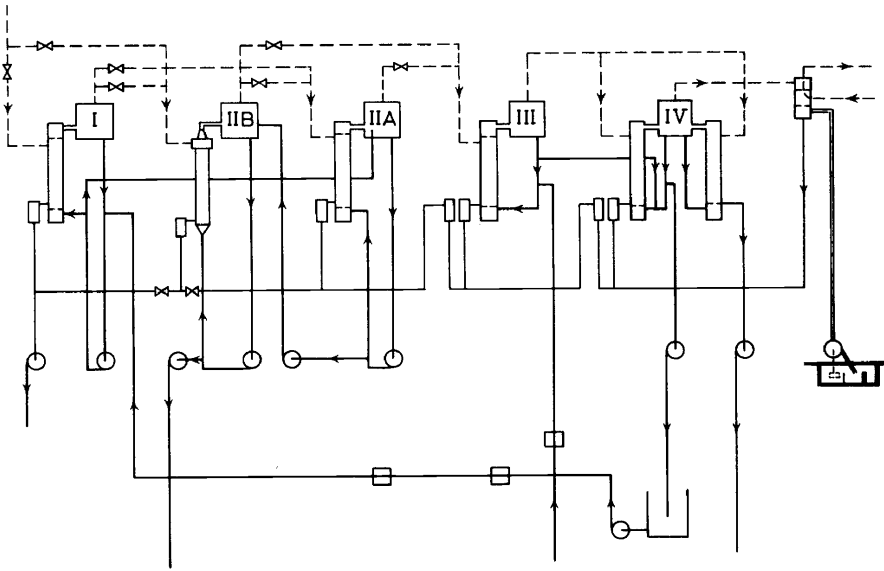

Figure 12. Evaporation plant for waste process water at a Swedish fibreboard mill

1.6 m<sup>3</sup> of waste water per ton of fibreboard produced. The capacity of the mill is 125000 tons of board per year or about 400 t/24 h. The waste water concentration is about 2.5 per cent.

The evaporation plant has five units, as shown in Figure 12. The fresh steam goes into units I or II B. The waste water enters unit III and goes

## WASTE WATER FROM FIBREBOARD MILLS

to unit IV, from which it is pumped to an equalizing tank in a half-evaporated state. From the tank the liquid passes unit I, II A and II B, any of which can be shut off for washing. After evaporation the concentrate has a concentration of about 40 per cent and is pumped to the boiler and burnt.

The fibreboard plant was extended about three years ago when the capacity was increased from 90000 to 125000 tons per year. At the same time the evaporation plant was extended by installing unit II B and by arranging for forced circulation also in units II A and II B. The forced circulation has decreased the need for washing the first units from daily washings to 8–10 times per year.

The cost for the waste water treatment of this mill is calculated to 6 to 7 Swedish Kr per ton (\$1.2–1.4/t). In this figure the fuel value of the concentrate has been taken into account.

*Figure 13* shows how a five unit evaporation plant would be built to-day with due regard to forced circulation in order to diminish the need for washing.

In a recent publication it is mentioned that the Masonite hardboard plant at Laurel, Miss., will evaporate some  $3\,250\text{ m}^3/24\text{ h}$  of waste water containing just over 100 t/24 h of  $\text{BOD}_5$  to produce 180 t/24 h of a concentrate to be used as cattle feed.

## HYDROLYSIS AND FODDER YEAST PRODUCTION

At a Rumanian fibreboard mill a press has been installed in order to obtain a reasonably concentrated waste water—4 to  $6\text{ m}^3/\text{t}$ . This water is sent to a special plant where it is hydrolyzed at  $125\text{--}130^\circ\text{C}$  and pH 1.7–1.8 for 2.5–4 hours. The raw material for the board production is beech and for that reason most of the oligo-saccharides dissolved during the pre-heating consist of pentosans, which form xylose and to some extent arabinose during the hydrolysis. In practice it has been possible to obtain 70–75 per cent of the total solids of the waste water as reducing sugars, calculated as xylose. There are also some hexoses formed during the hydrolysis.

In this plant—the first of its kind—some difficulties were encountered. During the hydrolysis a precipitate was formed which had a tendency to stick to the walls of tubes, and to some extent to clog the heat exchangers. Some of the precipitate remained suspended in the solution.

The hydrolysis plant is shown schematically in *Figure 14*. The waste water from the fibreboard plant is pumped to the equalizing tank A. A feed pump B forces the waste water through a heat exchanger G. The water is further heated with live steam in  $C_1$ . Sulphuric acid is added at D and the temperature of the acidified water is regulated by the addition of live steam at  $C_2$  before the solution enters the three reactors  $E_1$ ,  $E_2$ , and  $E_3$  coupled in series. The hydrolyzed water passes from  $E_3$  through the heat exchanger G to neutralization tank H. The partly neutralized solution is pumped by pump P into the fodder yeast plant. During the hydrolysis some solution is blown out through the automatic bottom blow valves  $F_1$ ,  $F_2$  and  $F_3$  to a cyclone J. The solution with suspended precipitate flows into the tank K, where the precipitate is partly sedimented. The solution with a small amount of the precipitate flows into the level box L and is pumped by pump

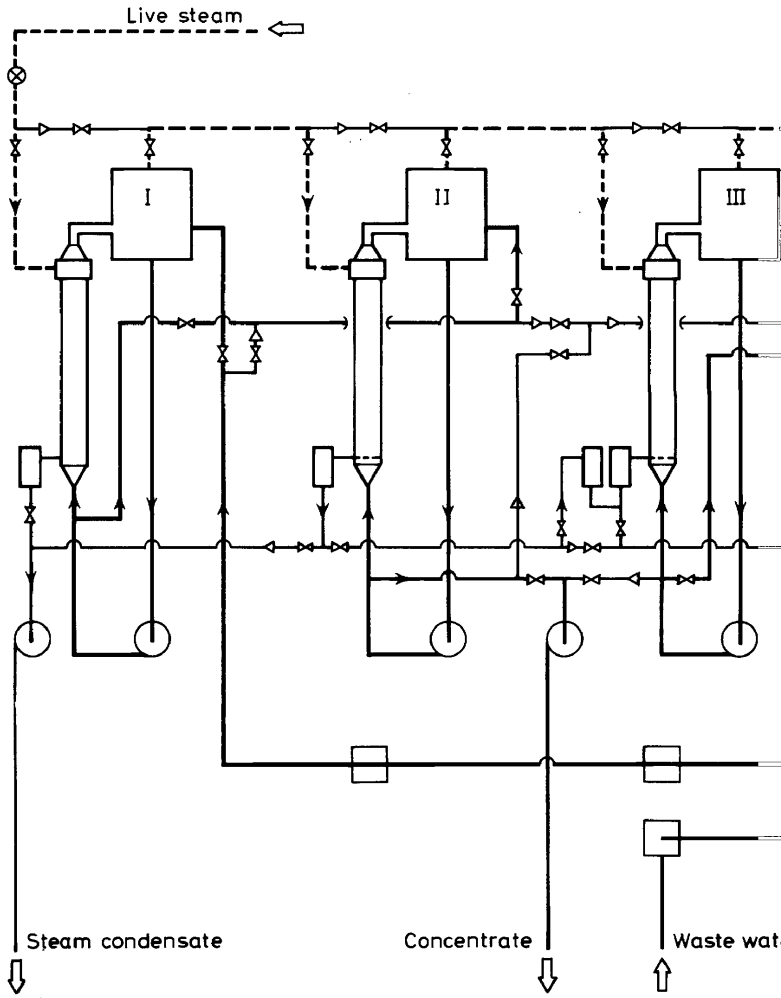
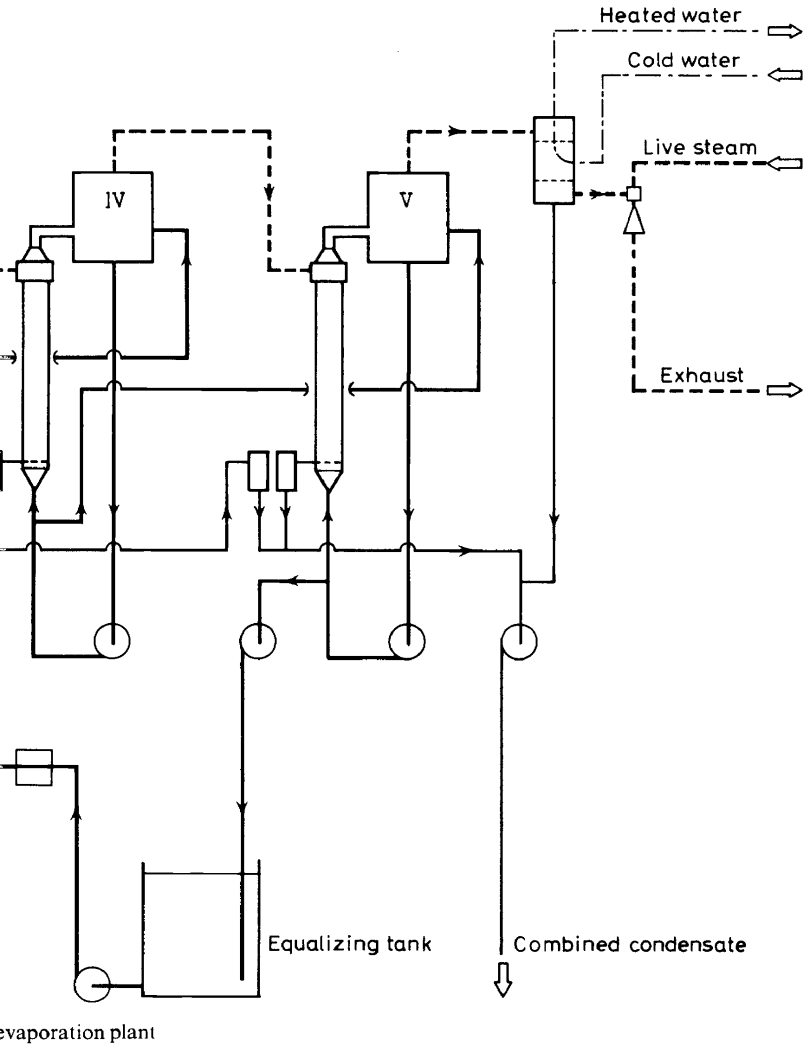

Figure 13. Diagram

# WASTE WATER FROM FIBREBOARD MILLS



M through hydrocyclones N. The acceptable portion goes to the neutralization tank H and the reject goes back to the tank K. The sedimented precipitate at the bottom of tank K is pumped by pump O to the fibreboard plant where it is mixed with the pulp.

The fodder yeast plant is of the same type as that used, for example, in the fermentation of sulphite waste liquor or molasses for the production of

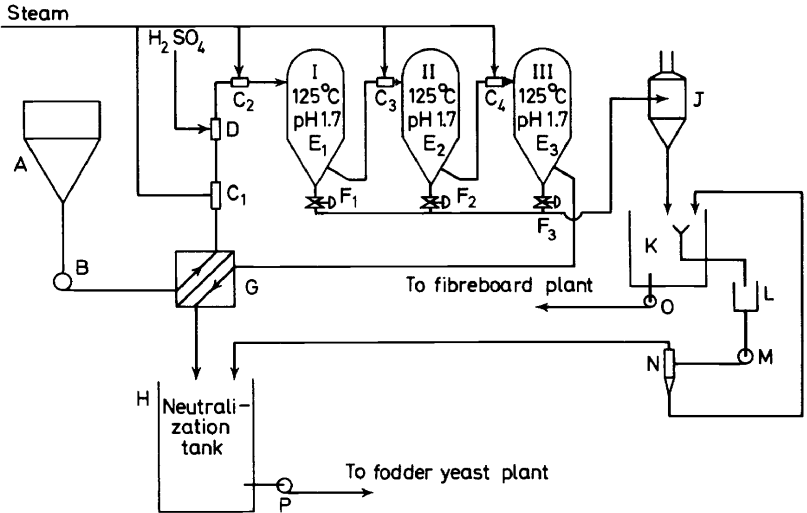

Figure 14. Hydrolysis for concentrated waste water at a Roumanian fibreboard mill

fodder yeast. The same type of yeast is also obtained. The yeast obtained from the hydrolyzed fibreboard waste water at the Rumanian plant is very light-coloured and is said to be of excellent quality.

Using this technique it seems possible to reduce the BOD load by some 65–70 per cent.

Installation costs are fairly high and so are operating costs. On the other hand, in case of protein shortage the method may be a suitable means of reducing the water pollution and at the same time producing a valuable feed-stuff.

## WET OXIDATION

In waste water treatment wet oxidation by air or oxygen—the Zimmermann process—is mentioned now and then. It is not known if this process has been tried in connection with fibreboard mill waste water.

Very recently a new wet oxidation process based on the use of a very effective catalyst and operating at atmospheric pressure has been mentioned. Such processes might be very interesting if they can compete economically with other waste water processing methods, as they do not produce any by-products which have to be removed.

## REVERSE OSMOSIS

During the last few years reverse osmosis has been tried repeatedly for the concentration of dilute waste waters in the pulping industries. Recoveries of excellent quality water well in excess of 80 per cent and at the same time concentrates in the 8–10 per cent solids range have demonstrated the technical capabilities of this method. No experiments seem to have been carried out on fibreboard waste water yet, and so far little seems to be known about actual costs.

The concentrates obtained in this process could most certainly be further processed for disposal by conventional methods such as evaporation and burning.

## OTHER METHODS

A number of other methods has been suggested for the disposal of waste water, such as treating them with ozone or pumping them into very deep holes drilled into the earth. However, it seems too early to pay any attention to these methods yet.

## REFERENCES

- <sup>1</sup> A. Asplund, *Water Pollution affecting the Wallboard Industry* Defibrator AB Publication 309-36:6. 52.
- <sup>2</sup> A. Asplund, *Svensk Papperstid* **52** (4), 79 (1949).
- <sup>3</sup> A. L. Caron and R. O. Blosser, *Pulp Paper* **41**, (32), 22 (1967).
- <sup>4</sup> A. Edhborg, "Studies on a Water-Soluble Material from the Masonite Process". *Acta Polytech. (Scand.)* No. 197 (1956).
- <sup>5</sup> G. Gran, *Norsk Skogind.* **21** (9), 314 (1967).
- <sup>6</sup> G. Gran, *Holzindustrie* **20** (6), 175 (1967) (Defibrator AB Publication 309-85T:6. 67).
- <sup>7</sup> B. Groth and R. Reinhall, *Norsk Skogind.* **15** (3), 3 (1961). English translation: Defibrator AB Publication 309-71E:3. 61.
- <sup>8</sup> B. Groth, *Papper Trä* **45** (6-7), (1963). English translation: Defibrator AB Publication 309-81E:7. 63.
- <sup>9</sup> F. Malmström, *Svensk Papperstid.* **70** (12), 401 (1967).
- <sup>10</sup> J. H. Matthews, "The use for Irrigation of Effluent from a Hardboard Mill". Internat. Consultation on Plywood and other Wood-Based Panel Products. FAO Background Paper 3.15. July 1963.
- <sup>11</sup> M. Nepper, *Purdue Univ. Eng. Bull. Ext. Ser.* No. 129, 884 (1967).
- <sup>12</sup> C. Parsons, *Purdue Univ. Eng. Bull. Ext. Ser.* No. 129, 602 (1967).
- <sup>13</sup> W. C. Parsons and Paul H. Woodruff, *TAPPI* **53** (3), 411 (1970).
- <sup>14</sup> L. Sohlman, *Svensk Papperstid.* **71** (17), 599 (1968).