

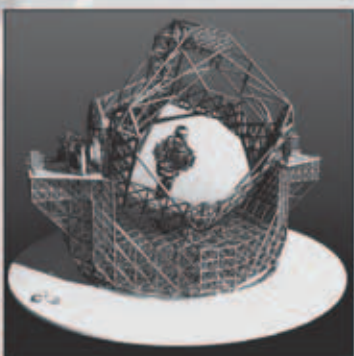

Model-Based Systems Engineering

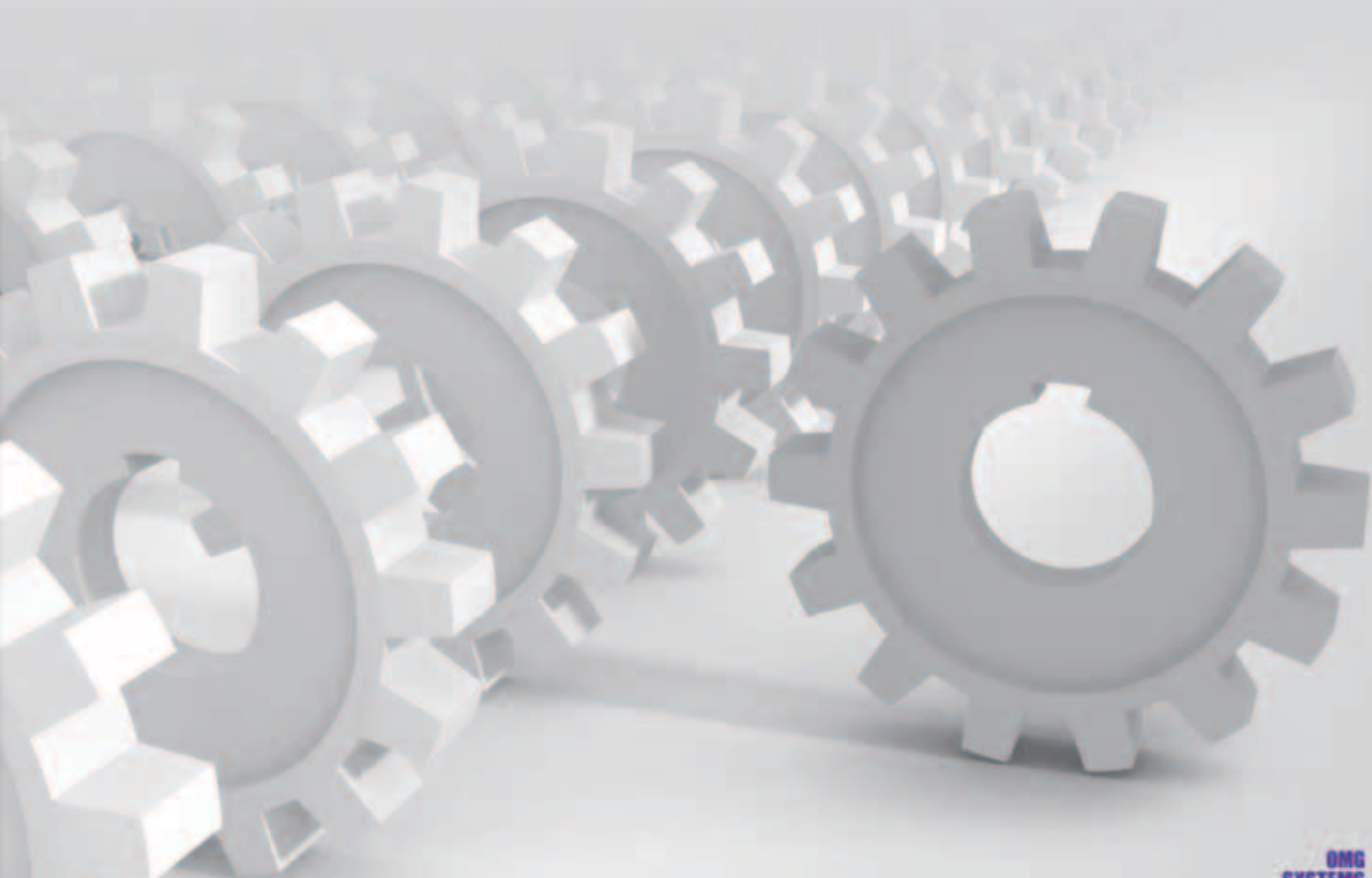

Model-based Systems Engineering

The Future Of Systems Engineering Is Model Based

The International Council on Systems Engineering (INCOSE) is defining a 15-year view of the evolution of the systems engineering discipline. Systems Engineering Vision 2020 reflects current practice, trends in industry, government and academia, and projects a vision of the state-of-the-art for 2020. It addresses the future systems engineering environment, systems architecting, systems development, systems management systems engineering standards, and systems engineering education and research.

The vision focuses on the Model-based systems engineering (MBSE) as the formalized application of modeling to support system requirements, design, analysis, verification and validation, beginning in the conceptual design phase and continuing throughout development and later life cycle phases. MBSE is expected to play an increasing role in the practice of systems engineering over the next several years.

MBSE Benefits

MBSE enhances the ability to capture, analyze, share, and manage the information associated with the complete specification of a product, resulting in the following benefits:

- Improved communications among the development stakeholders (e.g. the customer, program management, systems engineers, hardware and software developers, testers, and specialty engineering disciplines).
- Increased ability to manage system complexity by enabling a system model to be viewed from multiple perspectives, and to analyze the impact of changes.
- Improved product quality by providing an unambiguous and precise model of the system that can be evaluated for consistency, correctness, and completeness.
- Enhanced knowledge capture and reuse of the information by capturing information in more standardized ways and leveraging built in abstraction mechanisms inherent in model driven approaches. This in turn can result in reduced cycle time and lower maintenance costs to modify the design.
- Improved ability to teach and learn systems engineering fundamentals by providing a clear and unambiguous representation of the concepts.

SysML – Systems Modeling Language

Integration of Systems Engineering models with other discipline-specific models (software, hardware, simulation & analysis, etc.) is a primary need for system engineers. Therefore, a versatile modeling language unifying multiple languages used by system engineers, similar to UML in Software Engineering discipline, is essential.

SysML is the response to the UML for system engineer request for proposal, issued by the OMG in March 2003. In summary, SysML was designed with “real” systems in mind (where UML is software oriented).

SysML is a precise language, including support for constraints and parametric analysis, which allows models to be analyzed and simulated, greatly improving the value of system model, compared to textual system descriptions.

System Engineering with MagicDraw

The MagicDraw SysML plug-in retains all capabilities of award-winning MagicDraw modeling environment with System Engineer perspective, which provides domain specific modeling, analysis, and simulation capabilities.

The Best SysML implementation On Market

MagicDraw modeling solutions are well known for the best OMG standards support including UML, XMI, SysML, UPDM, BPMN, FUMML and others.

MagicDraw System Engineering solution includes full SysML standard implementation including complete SysML profile, all SysML diagrams, correctness and completeness constraints and non-normative extensions for EFFBD, MoE, QUDV, SYSMOD and others.

SysML, by providing a formal language for sharing system information among all project stakeholders, improves communication across team members, and also between teams. By offering a more complete representation of systems, SysML helps reducing errors and ambiguities during system development processes.

SysML is based on UML, which ensures that the flow of information from system engineers to software engineers is more accurate. Being an open standard, which supports XMI and ISO 10303-303 (AP233), SysML allows information interchange to other Systems Engineering tools (model interoperability among tools) such as CAD, electrical and engineering analysis tools.

The majority of SysML book authors, OMG and INCOSE MBSE working groups use MagicDraw SysML tool to produce 100% compliant SysML models and high quality scalable publishing-ready diagrams. The default built-in example HSUV model is used by OMG to produce sample diagrams for SysML specification document.

Library For Quantities, Units, Dimensions and Values (QUDV)

For any system model, a solid foundation of well-defined quantities, units and dimensions system is very important.

QUDV supports specific systems of quantities and units, including precise definitions of the relationships between different systems of units, and with explicit and unambiguous unit conversions to and from SI as well as other systems. Our QUDV library includes SysML ValueTypes library for International System of Units (SI).

Requirements Engineering

The increasing complexity of systems makes Requirements Engineering (RE) a critical phase in a system's life cycle.

SysML requirements modeling constructs are intended to provide a bridge between traditional requirements management tools and system models. Requirements can be imported or defined in MagicDraw and depicted in graphical, tabular, matrix or tree structure format. A requirement can also appear on other diagrams to show its relationship to other modeling elements deriving, satisfying, verifying or refining requirements

Key Features:

- Requirements diagram
- Requirements Table allows organizing text-based requirements in spreadsheet-like tabular format.
- Satisfy and Verify matrices provides traceability of requirements with ability to quickly add new relation.
- Cameo™ DataHub add-on allows import, export, synchronize, and reference text based requirements in Cameo™ Requirements+, IBM Rational DOORS, Rational RequisitePro and Microsoft Excel.

Execution and Simulation

No Magic is the first in the industry to provide extendable model execution framework based on OMG fUML and W3C SCXML standards. Cameo Simulation Toolkit extends MagicDraw capabilities and allows validating system behavior by executing, animating, and debugging UML 2.0 StateMachine and Activity models in the context of realistic mock-ups of the intended user interface.

Key Features:

- StateMachine execution (W3C SCXML engine, SCXML file export)
- UML 2.0 Activities execution (full OMG™ fUML standard support)
- SysML parametric diagrams solving
- Multiple action languages (JSR 223: Scripting for the Java Platform)
- Model debugger with animation in diagrams
- Quick UI prototyping - User Interface Modeling Diagrams
- Runtime snapshots to Instances model
- Execution trace recording and analysis
- Model-driven test cases
- API for custom domain specific extensions

Solving Parametric Models and System MoEs

SysML Constraint blocks are used to specify a network of reusable constraints that represent mathematical expressions, which constrain the physical properties of a system (e.g. physics laws) or calculate system MoEs (measure of effectiveness), e.g. cost, risk, performance, reliability etc.

- **Cameo Simulation Toolkit** dynamically solves constraints in the context of full system simulation and allows tracking and maintaining dependencies among critical parameters such as size, weight, speed, power, temperature and others throughout the system life cycle.

- **Paramagic Plugin** allows performing parametric trade studies and “what-if” scenarios by swapping given and target values in SysML instance models, which capture design alternatives, without modifying the parametric model.

Huge amount of input values can be obtained from integrated MS Excel spreadsheets or real sensors. Expressions are solved using build-in math solver and/or interfaces to well-known solvers such as Matlab, Mathematica and OpenModelica.

Correctness and Completeness Analysis

- Model validation: passive (ad-hoc) validation and active (real-time) validation, allowing validate the conformity of SysML model against a set of validation rules, namely validation suite, and ensure model is well-formed.
- Custom validation rules can be defined by using OCL, Java and other languages.

Wide Choice Of Customizable Reports

- Customizable Velocity templates. Use report generation engine to quickly produce comprehensive, professional requirements, design, documentation, and other types of reports in HTML and RTF formats.
- Web Publisher – dynamic, web-ready browsable report with commenting capability + iPhone/iPad reader
- DocBook plugin allows to model your document structure and generate standard-based DocBook XML.
- Batch mode nightly reports.

Other Unique Features

- Structure Browser allows viewing and manipulating assembled system in a new revolutionary way.
- Automatic instantiation of complex structures – create large Instance models in few clicks.
- Context Specific Values compartments – shows values of chosen instance model (design alternative) in IBD.
- “Extract Structure” feature allows transforming part of reusable structure into new Block/Part.
- Activity decomposition wizard: automatic creation of a hierarchy of Activities in a Block Definition Diagram.
- UPDM extends systems modeling within Systems views in military architecture frameworks.
- MARTE profile adds capabilities for modeling Real Time and Embedded Systems (RTES).
- SYSMOD profile provides a toolbox for Systems Modeling Process support.

Our Customers

NASA JPL, General Electrics (GE Aviation, GE Healthcare), Lockheed Martin, European Southern Observatory, European Space Agency, Northrop Grumman, US Army, Sandia National Laboratories, Teledyne Brown Engineering, Raytheon, BMW Group, BAE Systems, Cisco Systems, Siemens AG and others.

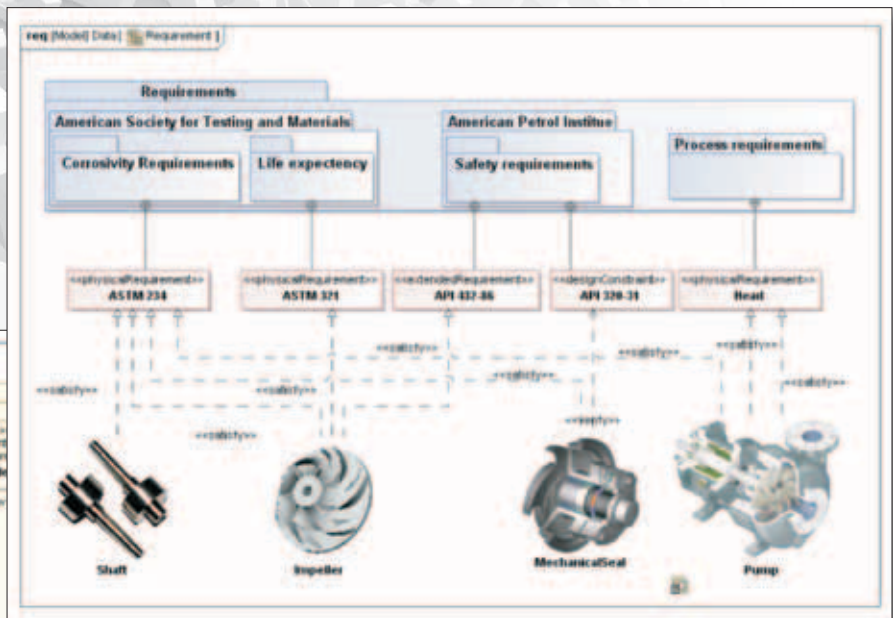

Requirements Diagram (req)

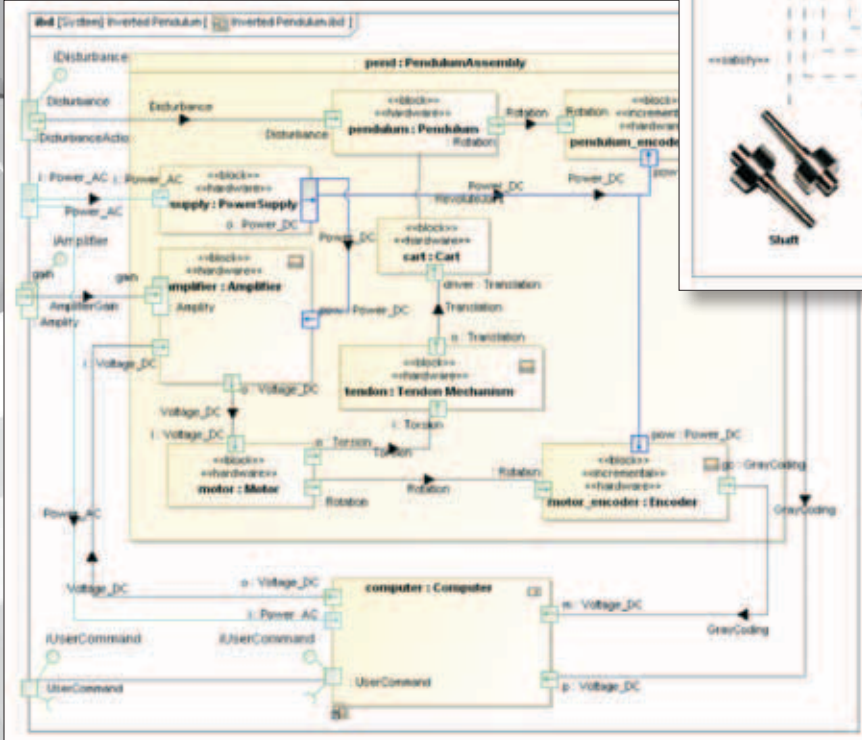

Internal Block Diagram (ibd)

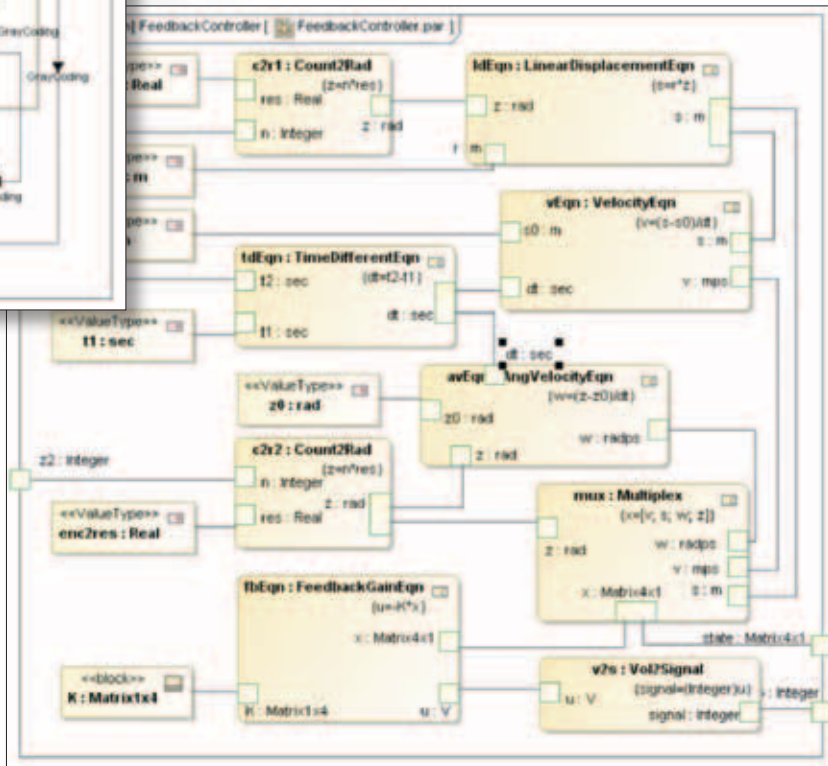

Parametric Diagram (par)

No Magic, Inc.

www.magicdraw.com

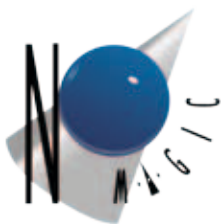

Corporate Headquarters

7304 Alma Drive, Suite 600
 Plano, TX 75025
 Phone: 214.291.9100
 Fax: 214.291.9099
 E-mail: sales@nomagic.com

No Magic Europe, UAB

Savanoriu ave. 363
 LT-49425, Kaunas, Lithuania
 Phone: +370 37 324 032
 Fax: +370 37 320 670
 kontaktai@nomagic.lt

No Magic Asia

719 KPN Tower, 22nd floor,
 Rama IX Road, Bangkapi, Huaykwang,
 Bangkok 10310, Thailand
 Phone: +66 2717 0250
 Fax: +66 2717 0251
 E-mail: nomagicth@nomagicasia.com

The Truth is in the Models™
 www.nomagic.com

Copyright © 2011 No Magic, Inc. MagicDraw is a registered trademark of No Magic, Inc.
 UML logo is a registered trademark of the Object Management Group. SysML logo is a registered trademark of the Object Management Group.